

---

# Table of Contents

## F01 Workbook - Module 1

Subject	Page
<b>The New 7 Series for 2009</b> .....	<b>9</b>
Introduction of the F01/F02 .....	9
Comparison of F01 to F02 .....	10
Dimensional Comparison .....	11
<b>Powertrain</b> .....	<b>18</b>
Changes to Powertrain .....	18
Engine Electrical System .....	19
Engine Control Unit .....	19
System Bleeding .....	19
Cooling System .....	20
Charge Air Cooling .....	21
Coolant Pump .....	21
Fuel System F01/F02 .....	24
Fuel Supply System .....	24
Pressure Limiting Valve .....	25
Fuel Tank Breather System .....	26
Automatic Transmission .....	30
Gear Selector Switch .....	30
Emergency Release .....	30
Rear Axle Differential .....	30
Driveshaft and Axles .....	31
Axle Shafts .....	31

---

# Table of Contents

Subject	Page
<b>Bus Systems</b> .....	<b>34</b>
Overview of the Bus Systems in the F01/F02 .....	38
Bus Systems .....	38
Structure in Vehicle .....	38
Overall Network of the F01/F02 .....	38
Overview of Bus Systems .....	39
Main Bus Systems .....	39
Changes to Main Bus Systems .....	39
Diagnosis Can (D-CAN) .....	40
Location of D-CAN Connection .....	40
K-CAN .....	41
K-CAN 2 .....	41
PT-CAN .....	42
PT-CAN 2 .....	42
Ethernet .....	43
Application in the F01/F02 .....	43
Security .....	43
FlexRay - Application in the F01/F02 .....	44
FlexRay Bus Topology on the F01 .....	44
Bus Termination .....	45
Wiring .....	46
Measurements on the FlexRay .....	46
Wake-up and Sleep Characteristics .....	46
MOST Bus .....	47
The MOST Control Units and Light Direction .....	47
Light Direction .....	47
Fiber Optic Connector .....	47

---

# Table of Contents

Subject	Page
Sub-bus Systems .....	48
BSD .....	48
K-bus Protocol .....	48
Local CAN .....	48
LIN bus .....	48
LIN V2.0 (or V2.1) .....	49
LIN Bus Overview .....	50
<b>Voltage Supply .....</b>	<b>60</b>
Overview of System Components .....	60
Vehicle Battery .....	60
Distribution Box .....	60
Fuse Carriers .....	61
Front Fuse Carrier .....	62
Installation Location .....	62
Front Fuse Carrier and Junction Box Electronics .....	62
Relays in the Front Fuse Carrier .....	62
Connected relay .....	62
Soldered Relay .....	63
Rear Fuse Carrier in the Luggage Compartment .....	63
Power Distribution Box in Engine Compartment .....	64
Battery Cables .....	64
Intelligent Battery Sensor (IBS) .....	64
Voltage Supply Circuit Diagram .....	65

---

# Table of Contents

Subject	Page
<b>Energy Management</b> .....	<b>66</b>
Bus Overview and Terminal Status .....	67
Terminal 15N .....	67
Terminal 30B .....	67
Terminal 30F .....	68
Terminal Relays .....	70
General Measures .....	70
Intelligent Battery Sensor (IBS) .....	71
Wake-up Function .....	71
Commissioning .....	72
Junction Box Module .....	72
Engine Management (power management) .....	72
Transport Mode .....	73
Closed-circuit Current .....	74
Electrical System and Battery Diagnosis .....	75
<b>Car Access System</b> .....	<b>80</b>
CAS 4 .....	80
Functional Overview .....	80
ID transmitter search in passenger compartment .....	81
Input/Output CAS 4 .....	82
Electronic Immobilizer 4 .....	83
Design of the EWS 4 System .....	83
Start enable through the electronic vehicle immobilizer .....	83
Data Transmission .....	84
Secret Key .....	84
Gearbox Enable .....	84

---

# Table of Contents

Subject	Page
Start Value Matching .....	84
Components of the Car Access System .....	85
CAS 4 .....	85
START-STOP Button .....	85
Emergency Start Coil .....	85
Remote Control Receiver .....	86
Input Components .....	86
Vehicle Data Storage .....	86
Updating Service Data .....	87
Updating Service Key Data .....	87
Automatic Updating .....	87
Manual Updating .....	88
Control Unit Replacement .....	88
<b>Electronic Systems .....</b>	<b>90</b>
Comfort Access System .....	90
Component Location Overview .....	91
Location of Antennas .....	91
Central Locking .....	92
Input/Output Central Locking .....	92
Operation of Central Locking .....	93
K-CAN 2 signals at CAS 4 .....	93
Power Windows .....	94
Activation Example .....	94
Input/Output Power Windows .....	94
Power Window Operation .....	95
Examples of the Signal Path .....	95

---

# Table of Contents

Subject	Page
Driver's door switch cluster .....	95
Power window switch, front passenger's door .....	95
Power window switch, rear doors .....	95
Sliding/Tilting Sunroof .....	96
Slide/tilt Sunroof Operating Concept .....	96
Input/Output Sliding/tilting Sunroof .....	96
System Diagram .....	97
K-CAN 2 Signals at FZD .....	97
Alarm System (DWA) .....	98
Overview .....	98
Alarm System Schematic .....	98
Activating the Anti-theft Alarm .....	99
Deactivating tilt sensor and ultrasonic interior sensor (USIS) .....	100
Deactivating the anti-theft alarm system .....	100
Unlocking the trunk .....	100
No crosswise operation .....	100
Alarm System Feedback .....	100
Feedback via DWA LED .....	100
Confirmation from turn signal indicators .....	101
Confirmation via the emergency power siren .....	101
Comfort Access .....	101
Windshield Wiping/Washing .....	102
Automatic Wipe .....	102
Components .....	103
Steering column switch cluster .....	103
Junction box electronics .....	103
Dynamic stability control .....	103

---

# Table of Contents

Subject	Page
Rain/lights/solar/condensation sensor .....	103
System Circuit Diagram for Wiper/washer System .....	104
Outside Rear View Mirrors .....	106
Schematic, Outside Rear View Mirrors .....	107
Steering Column Switch Cluster .....	108
Steering Wheel .....	108
Schematic, SZL and Steering Wheel Electronics .....	109
Exterior Lighting System with Adaptive Headlights .....	110
Overview .....	110
Schematic, Exterior Lighting Front .....	111
Schematic, Exterior Lighting Rear .....	112
Adaptive Headlight-range Adjustment .....	113
Seats .....	114
Passenger-assist Function .....	114
Rear Seats .....	114
Rear Comfort Seat, Driver's Side .....	115
Massage function in Rear-compartment Comfort Seat .....	116
Massage .....	117
Mobilization .....	117
Active Seat Ventilation for the Rear Comfort Seat .....	118
Air-conditioning Pad .....	119

# Workbook - Module 1

**Model: F01/F02**

**Production: From Start of Production**

# OBJECTIVES

After completion of this module you will be able to:

- Locate and identify components of the F01/F02
- Understand the powertrain systems on the F01/F02
- Understand the changes to the bus network on the F01/F02
- Understand the voltage supply and energy management systems on the F01/F02
- Understand basic systems and functions on the F01/F02



# The New 7 Series for 2009

## Introduction of the F01/F02

In the late fall of 2008, the F01 will be in production in the Dingolfing plant. At the same time, the F02 (long-wheelbase version) will start coming off the assembly line.

For the US market, the 750i and 750Li will be offered with the already known N63 engine. The F01/F02 is lower in height than the E65/E66 and it has an improved rear passenger compartment area (space for head/knees). The overall wheelbase has been increased as well. The headroom and luggage-compartment capacity are more or less the same as in the E65.

**F01**



**F02**



The F01 represents the 5th generation of the BMW 7 Series flagship sedan. In addition to being the pinnacle of luxury, the new 7 series also combines the new engine and chassis systems to deliver class leading performance. With the already proven N63 engine, the F01 is more than capable of delivering on the promise of “Efficient Dynamics” which encompasses performance as well as the best possible fuel efficiency.

As in the past, the 7 Series is packed with the latest innovations in driver information and assistance systems. Some of these optional innovations include ACC Stop and Go, Night Vision 2, Lane Departure Warning, Active Blind Spot Detection as well as rear view and side view camera systems.

To complement the many new developments on the 7 Series, there is also a new rear wheel steering system which is part of the new “Integral Active Steering System”. This is the first time such a system has been installed on a BMW sedan. This system as well as many other innovations and developments will be covered during the progression of this training course.

*For more detailed information, please refer to the reference material (course code - ST811) which can be found on ICP or TIS.*

## Comparison of F01 to F02

- Wheelbase longer by 140 mm
- F02 rear axle with pneumatic springs and self-leveling suspension (EHC) as standard
- F02 has more rear-passenger orientation and a multifunction seat with improved comfort

The suspension damping is variable, with 3-stage adjustment. The steering is an Integral Active Steering configuration with steerable rear axle.

Driver assistance systems and a cockpit arrangement with driver orientation and a centrally located gear selector lever are distinct from the E65.

New options available for the F01/F02 as compared to the E65:

- Head-Up Display
- Massage function for comfort seats in the rear
- Sideview and rear view cameras
- 4-zone air conditioning
- Instrument panel finished in leather
- Ceramic secondary controls (optional)
- Lane Departure Warning
- Active Blind Spot Detection (a.k.a. Lane Change Warning)
- Night Vision with person recognition (Pedestrian Detection)
- Integral Active Steering
- ACC with Stop & Go function.

As the graphic indicates, in comparison with the F01 from the B-pillar back, the rear-seat passengers of the F02 have 140 mm more length and 10 mm more height at their disposal.

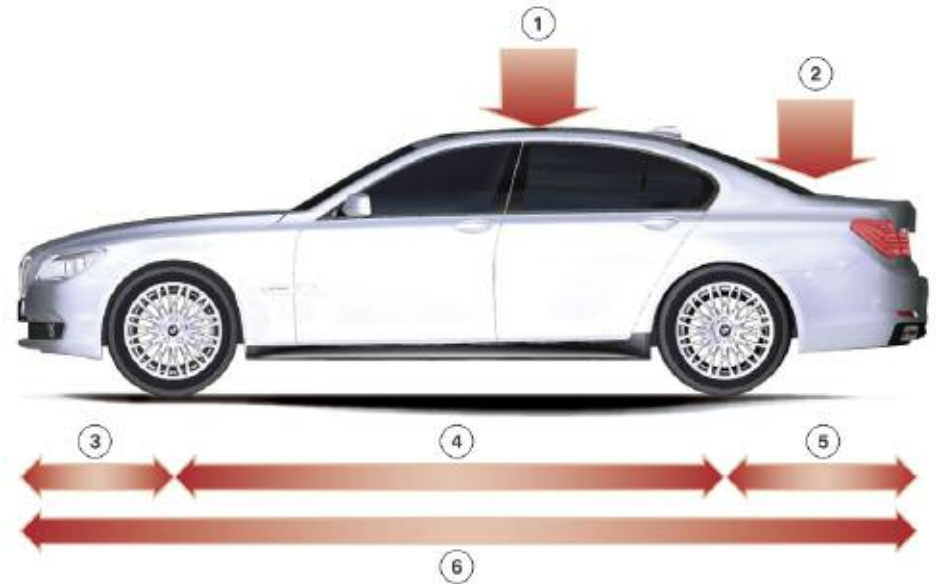

Index	Explanation	Index	Explanation
1	Lower	4	Longer (wheelbase)
2	Flatter	5	Longer
3	Shorter	6	Longer

Due to the “intelligent mix” of materials and the use of high strength steels, the torsional rigidity of the F01 has been improved as compared to the E65:

- E65 = 31,200 Nm per degree
- F01 = 37,500 Nm per degree

## Dimensional Comparison

As the graphic indicates, in comparison with the F01 from the B-pillar back the rear-seat passengers of the F02 have 140 mm more length and 10 mm more height at their disposal.

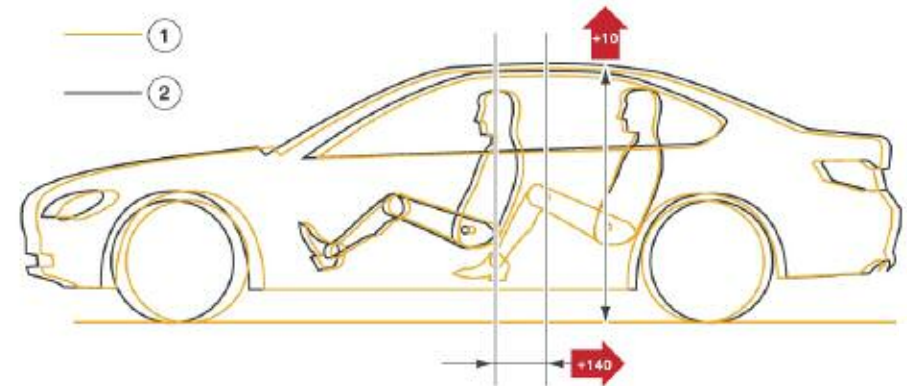
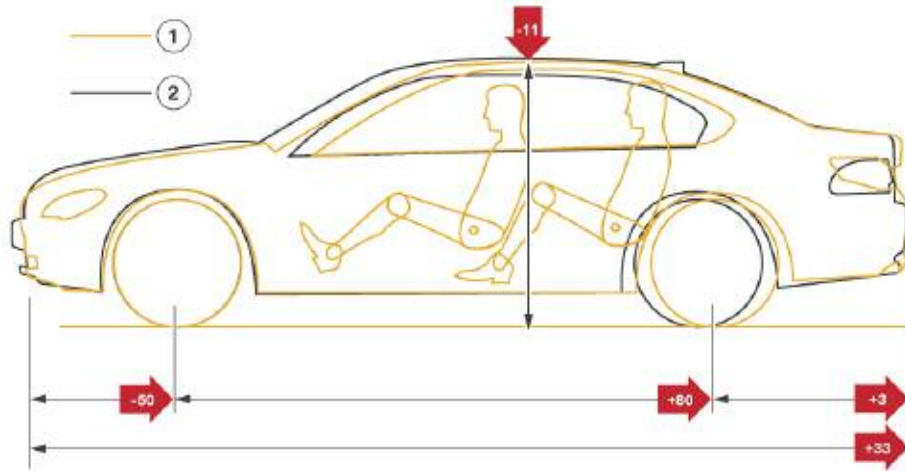

Index	Explanation	Index	Explanation
1	E65 facelift	2	F01

Index	Explanation	Index	Explanation
1	F01	2	F02

Explanation	E65	F01	E66	F02
Overall length	5039 mm	<b>5072 mm</b>	5179 mm	<b>5212 mm</b>
Wheelbase	2990 mm	<b>3070 mm</b>	3130 mm	<b>3210 mm</b>
Overhang, front	914 mm	864 mm	914 mm	864 mm
Overhang, rear	1135 mm	<b>1138 mm</b>	1135 mm	<b>1138 mm</b>
Vehicle Width	1902 mm	1902 mm	1902 mm	1902 mm
Front track width (basic wheel)	1578 mm	<b>1612 mm</b>	1578 mm	<b>1612 mm</b>
Rear track width (basic wheel)	1596 mm	<b>1646 mm</b>	1596 mm	<b>1646 mm</b>



## Workshop Exercise - Vehicle Walkaround

While performing the vehicle walk around, note the following items on the checklist and answer the pertinent questions.

**Tires and wheels**

Standard size \_\_\_\_\_

Optional size \_\_\_\_\_

What type of tires are used? \_\_\_\_\_

Is there a spare and/or a jack? \_\_\_\_\_

**PDC system (front and rear)**

What is different about the PDC system?

\_\_\_\_\_

**Emergency release for transmission and EMF**

What is different about the emergency release tool?

\_\_\_\_\_

\_\_\_\_\_

**Mirrors, exterior rear view**

What is different about the exterior (side view) mirrors?

\_\_\_\_\_

\_\_\_\_\_

**Sunroof**

How does the sunroof differ from the previous 7 Series?

\_\_\_\_\_

\_\_\_\_\_

**Exterior sensors and cameras**

List the cameras and sensors for:

The front area -

\_\_\_\_\_

\_\_\_\_\_

\_\_\_\_\_

The rear area -

\_\_\_\_\_

\_\_\_\_\_

\_\_\_\_\_

**Note headlight bulb access:**

**Note E-Box location and DME (relocation)**

**Note coolant fill locations for engine and charge air cooling**



## Workshop Exercise - Vehicle Walkaround

With instructor assistance, perform a walkaround of the F01 and note the body construction. Complete the following exercise and answer the associated questions.

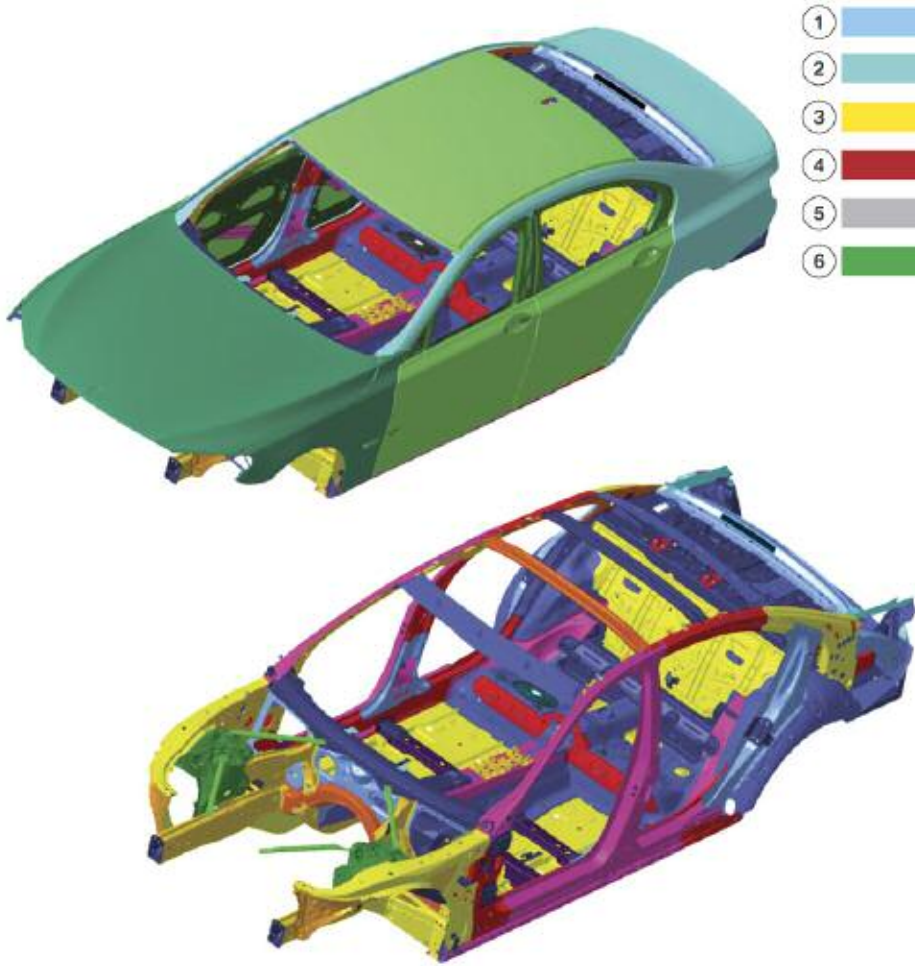

Fill in the materials used on the F01 using the color codes as a guide:

Item	Materials
Hood	
Fenders	
Front doors	
Rear doors	
Trunk lid	
Roof	
Rear quarter	

What is different about the roof construction on the F01?

---



---



---



---

Does the F01 use GRAV construction on the front end chassis components?

---



---



---



## Workshop Exercise - Exterior Lighting

Fill in the information regarding the exterior lighting in the spaces provided:

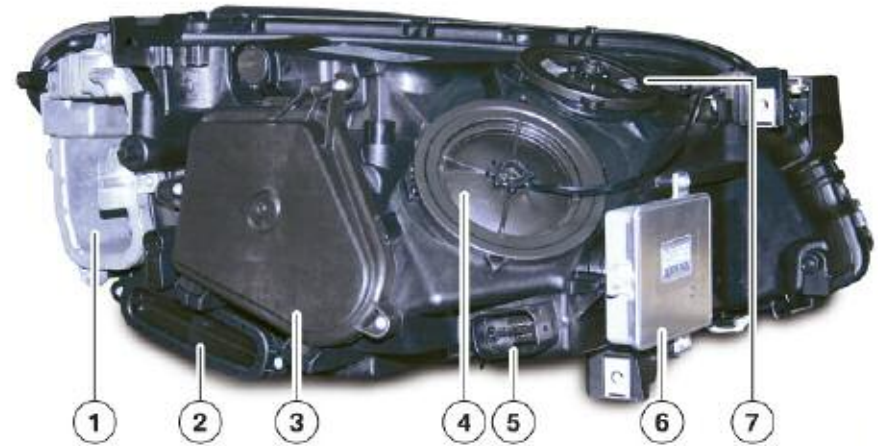

Index	Explanation
1	
2	
3	
4	
5	
6	
7	

Index	Explanation
1	
2	
3	
4	
5	
6	
7	





## Workshop Exercise - Exterior Lighting

Fill in the information regarding the exterior lighting in the spaces provided and answers :

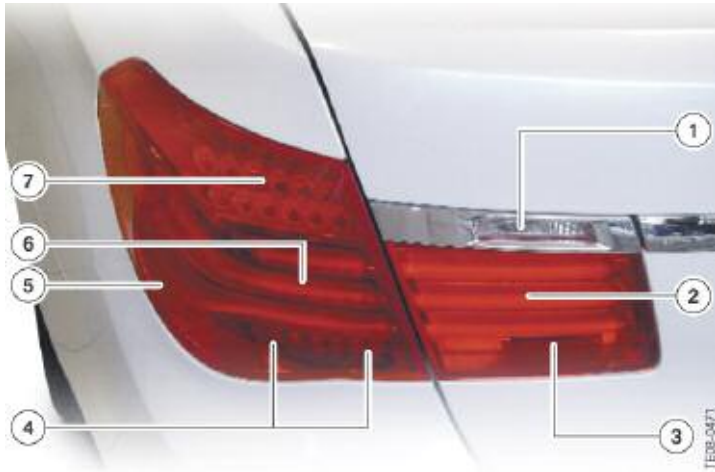

Index	Explanation
1	
2	
3	
4	
5	
6	
7	

What is used for the illumination of the reverse light?

---

---

What is common between all of the turn signals on the F01?

---

---

---

What module is considered the master control module for the exterior lighting?

---

---

What is the headlight driver module?

---

---

---



## Workshop Exercise - Door Handles and Rear View Mirror

Using the instructor assigned vehicle, remove the outer door handle and re-install using proper procedures. Complete exercise by answering the questions below.

Remove the plastic cover on the inner door jamb area.  
Locate the Torx head screw.

Using a suitable torx driver (must be more than XXX long), loosen the screw (counter clockwise) until it stops.

Remove the door handle and unplug the connectors.

Reverse procedure to re-install door handle. Re-tighten the screw only hand tight (do not overtighten).

Use the picture below for reference. This photo shows the internal view of the door handle attachment mechanism.



What size is the Torx driver needed?

---



---

What is different about the screw?

---



---



---

Using ISTA, locate the repair instructions for this procedure:

---



---



---

Are there any **“special”** tools required for this procedure?

---



---

Define the following terms in ISTA:

Index	Explanation	Index	Explanation
REP		FUB	
FTD		PIB	
AZD		ABL	
TED		SSP	





## Workshop Exercise - Door panel R&I

Remove the exterior rear (side) view mirror. Then proceed with the removal of the indicated door panel using proper procedures. Use ISTA to look up repair instructions.

Remove interior trim to access exterior (side view) mirror. Remove 3 bolts, unplug connector and remove mirror.

Using the BMW (wedge kit) remove the door panel trim carefully.



Is it necessary to remove the door panel trim to access and remove the side view mirror?

Remove the door panel trim and set aside.

Note the mounting of the window regulator (i.e. clips)

Re-install door trim panel and side view mirror.

Remove trim strip on door panel as indicated. Be sure to remove plastic pin **before** trim strip removal. (pin will fall into trim strip)



# Powertrain

## Changes to Powertrain

For the US market, the F01/02 will be introduced with the familiar N63 engine. For the most part, the engine is identical to the version introduced on the E71.

Mechanically, there are no changes to the engine. The primary differences exist in the form of ancillary components which are vehicle specific such as the exhaust, air intake ducting, cooling system, oil sump and engine electrical system.

The overview of the F01 powertrain includes the following:

- The engine management (DME) is now connected to the FlexRay bus in addition to the PT-CAN.
- The ECM (DME) is now water cooled via the cooling circuit for the charge air coolers.
- The fuel tank has been modified with additional breather valves as well as additional measures to reduce evaporative emissions.
- The low pressure fuel supply method is now a “pressure controlled” design which eliminates the pressure regulator in the fuel tank.
- The GA6HP26TU automatic transmission is carried over from the E70/71 with the dual damper torque converter.
- The rear differential is now made from aluminum for weight reduction. It has been optimized for low-friction operation.
- The driveshaft now uses the “push-fit” connection from the E70. For the first time, this is now a flexible connection.
- The rear axle shaft now have a “push-fit” connection at both ends. The F01 uses a solid axle shaft.



Index	F01/F02
Engine	N63B4400
Power output (hp)	400
Torque (Nm)	600
Exhaust emission standard	ULEV II
Transmission	GA6HP26TU
Rear axle differential	225AL
Final drive ratio	3.462

## Engine Electrical System

### Engine Control Unit

In the F01/F02, the N63 engine is controlled by the MSD85 as is the case in the E71. This control unit has been modified to make it compatible with the FlexRay used in the F01/F02.



Index	Explanation	Index	Explanation
1	Sealing frame	5	Coolant line
2	E-box cover	6	Engine Control Module (ECM)
3	Coolant return	7	Electronics box
4	Coolant supply		

The ECM (DME) is located to the front of the right-side spring strut dome. The ECM is now water cooled via a circuit which is adapted from the charge air cooling circuit.

The lower section of the electronics box is open to the outside. The upper section, which contains the connections, has a water-tight seal.

### System Bleeding

When servicing the ECM or any cooling system components within the charge air cooling circuit, the system must be bled of any trapped air.

In order to do this, the system is bled much the same way as vehicles with the N54 engine. See the “Workshop Exercise - Cooling System” in this workbook.

## Cooling System

In principle, the complex cooling system of the N63 engine is a carry-over from the E71.

Nevertheless, there are a few differences:

- no separate auxiliary coolant radiator
- engine oil radiator to the front of the left side wheel housing
- an additional engine oil radiator to the front of the right side wheel housing
- water-cooled engine control unit.

The cooling system comprises two separate cooling circuits as it did before. One cools the engine, one cools the charge air.

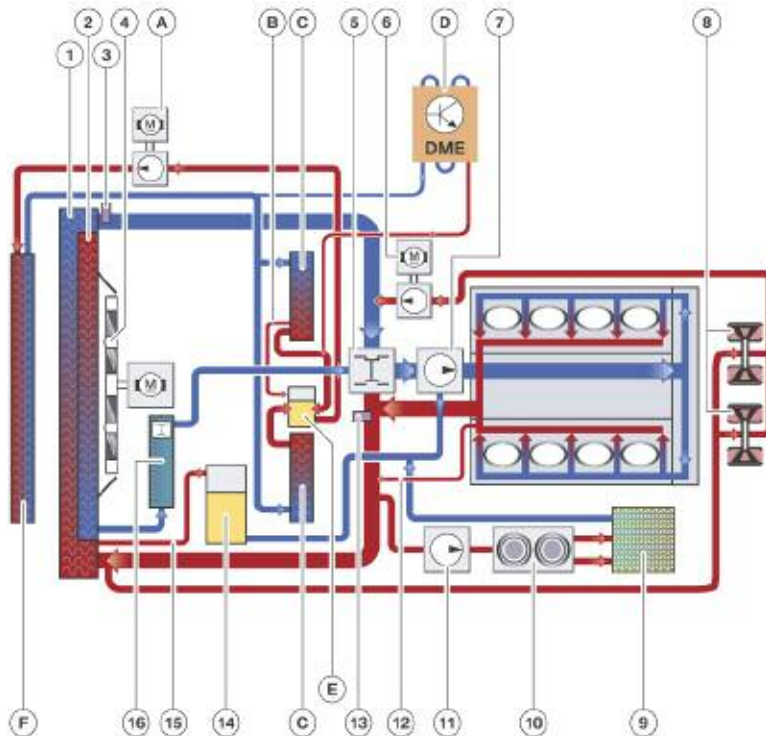

Index	Explanation	Index	Explanation
1	Radiator	12	Bleed line
2	Radiator for transmission cooling	13	Coolant temperature sensor, engine outlet
3	Coolant temperature sensor, radiator outlet	14	Expansion tank
4	Electric fan	15	Bleed line
5	Characteristic map thermostat	16	Transmission fluid-to-coolant heat exchanger
6	Electric auxiliary coolant pump for turbocharger cooling	A	Electric coolant pump for charge-air cooling
7	Coolant pump, belt driven	B	Bleed line
8	Exhaust turbocharger	C	Charge-air cooler
9	Heat exchanger for heating system	D	Digital Motor Electronics
10	Duo-valve (water valves)	E	Expansion tank for charge-air cooling
11	Electric auxiliary coolant pump for vehicle heating (IHKA)	F	Radiator for charge-air cooling

The only obvious difference is that no auxiliary coolant radiator is used in the F01/F02. This is made possible by the use of high-performance coolant radiators. These also have a more compact height, which is essential when it comes to pedestrian safety.

As usual, the coolant radiator has an integrated low-temperature section for transmission cooling.

Thanks to the on-demand control of the electric fan, the characteristic map thermostat and the electric auxiliary coolant pump, the thermal management system yields benefits in terms of fuel economy, comfort and power output.

The entire cooling module and the engine oil radiator and its lines are decoupled from the body in order to optimize sound characteristics in the passenger compartment.

## Charge Air Cooling

As it did in the E71, the turbocharged N63 engine operates with an indirect form of charge air cooling. Heat from the charge air is transferred to the coolant, then the hot coolant radiates heat into the ambient air.

There is a dedicated coolant circuit for this function. In the F01/F02, the cooling for the DME is also integrated into this coolant circuit. For the first time at BMW, the engine control unit is liquid-cooled.

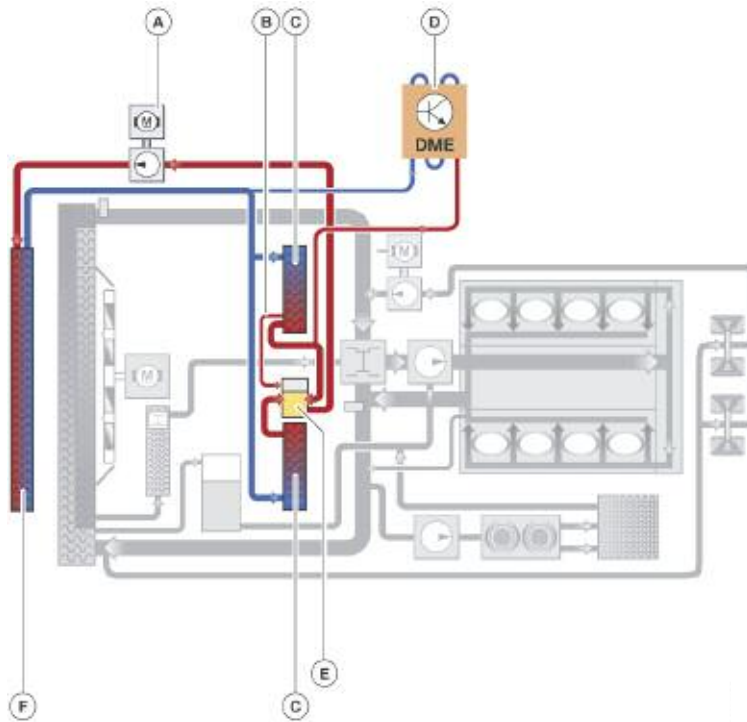

Index	Explanation	Index	Explanation
A	Electric coolant pump for charge air cooling	D	Digital Motor Electronics
B	Bleed line	E	Expansion tank for charge-air cooling
C	Charge air cooler	F	Radiator for charge-air cooling

## ■ Coolant Pump

The coolant pump for the charge air cooling system is connected to the ECM (DME) via the LIN bus.







## Workshop Exercise - Engine Control Module R&I

Using the instructor specified vehicle, remove the ECM (DME) from the E-box following the instructor's guidelines and proper procedures. Then, re-install the ECM and bleed cooling system.

With ignition off (KL0), remove cover from DME housing (4 Torx screws).

Unclip cover and remove



Unclip and remove white plastic sealing retainer from DME housing.



Disconnect wiring harness (5 plugs), unclip plastic retainer and remove grommets.



Remove DME from housing.



Remove harnesses from DME housing and secure harness and connectors from coming into contact with coolant. (use bungee cord or suitable tie straps).



Unclip DME housing from metal bracket. Lift up housing slightly to disconnect coolant lines. (a small amount of coolant will drain out, make sure there is a pan under the vehicle to catch the coolant.)





## Workshop Exercise - Engine Control Module R & I

Using the instructor specified vehicle, remove the ECM (DME) from the E-box following the instructor's guidelines and proper procedures. Then, re-install the ECM and bleed cooling system.

Re-install DME into housing, Re-connect coolant lines and re-install DME housing into vehicle.

Follow the reverse steps of the removal procedure.

Once the installation is complete, add the coolant from the drain pan and following the bleeding procedures as follows:

- Fill system with coolant via the expansion tank (AGB). Top up coolant level to lower edge of expansion tank.
- Close expansion tank.
- Switch on ignition.
- Set heating to maximum (temperature), switch on blower to lowest stage.
- Press accelerator pedal module to floor for at least 10 seconds. The engine must NOT be started.
- Bleeding via EWP takes approximately 12 minutes. Then check coolant level in expansion tank, top up to MAX marking if necessary.
- Check cooling circuit for leaks.
- If the procedure needs to be repeated several times, allow DME to completely de-energize (remove ignition key for approximately 3 minutes) and then repeat procedure as from item 3.

What part of the DME housing is "water-proof"?

---

---

---

What portion of the cooling system is used to cool the DME?

---

---

---

Are there any cooling fans in the DME housing?

---

---

---

Why was it necessary to relocate the DME to this position in the engine compartment?

---

---

---

---

**Note: Connect battery charger if battery charge level is low.**

## Fuel System F01/F02

The fuel system on the F01/02 has gone under some design changes as compared to previous models. The familiar fuel tank with divided chambers is still in use. The familiar configuration which features the fuel pump on the right (passenger) side is also retained.

### Fuel Supply System

In order to comply with the regulations regarding evaporative emissions, there have been several changes to internal fuel tank components as well as the fuel tank itself.

The fuel supply system has also been modified to eliminate the fuel pressure regulator. The following text summarizes the changes to the fuel supply system:

- the fuel supply system is now “pressure controlled”.
- the fuel pressure regulator has been replaced by the “pressure limiting valve” (8).
- the pressure in the fuel supply system is limited to a maximum of 5.8 bar by the pressure limiting valve (8).
- the EKPS will control the fuel pump in order to deliver only the amount of fuel required based on information from the fuel pressure sensor (low pressure).

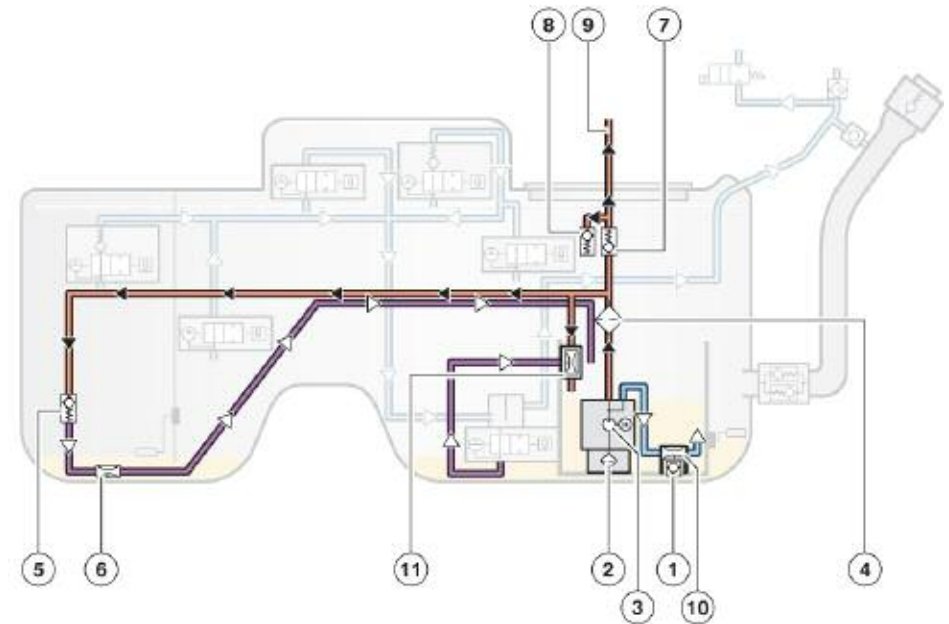

Index	Explanation	Index	Explanation
1	Initial fill valve	7	Anti-leak valve
2	Intake mesh filter	8	Pressure limiting valve
3	Fuel pump	9	Feed line
4	Fuel filter	10	Suction jet pump
5	Non-return valve	11	Suction jet pump
6	Suction jet pump		



## ■ Pressure Limiting Valve

The pressure limiting valve is connected to ground by the plug-in contacts on the service cover. This prevents electrostatic charge on the valve.

The pressure limiting valve keeps fuel pressures in the feed section lower than approximately 5.8 bar in the N63 engines

This prevents excess pressures from building up in the feed line. Excess pressures would otherwise occur if the fuel filter were to become blocked, which would place the feed section of the fuel system under unnecessarily heavy loads.

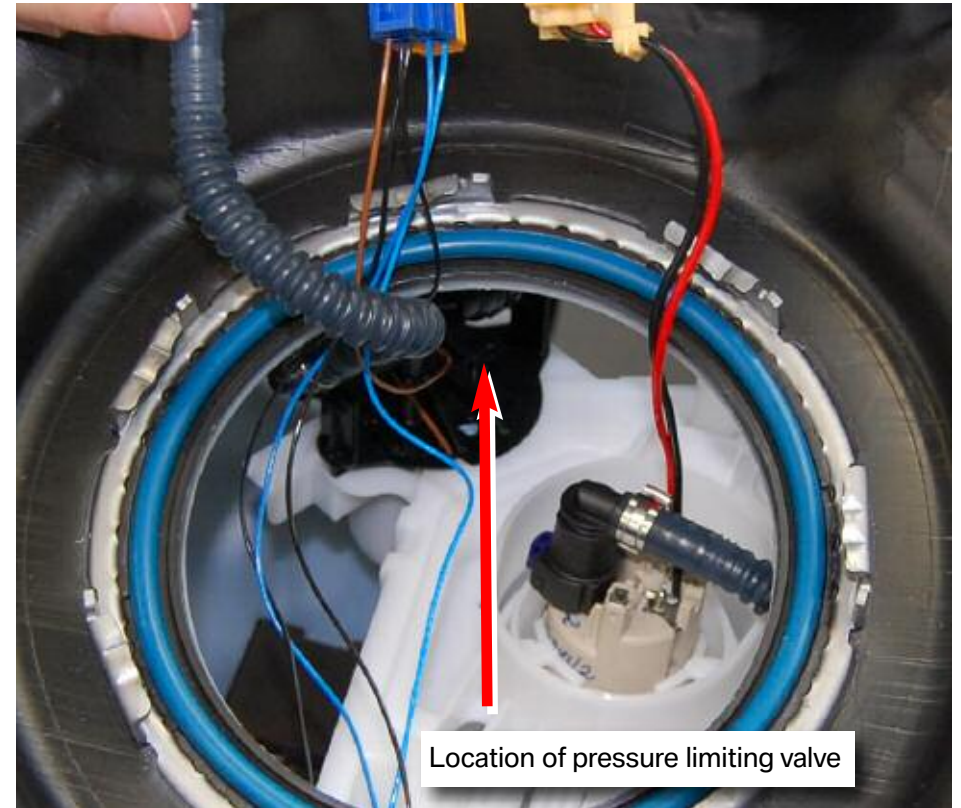
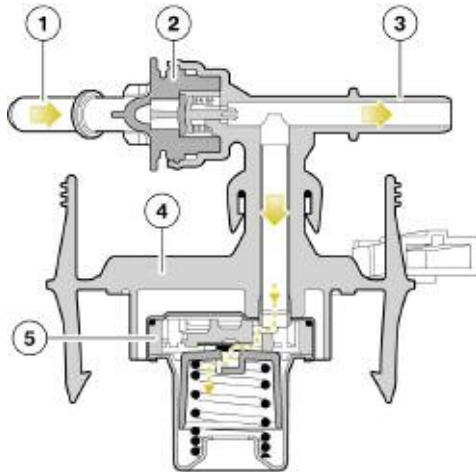

Index	Explanation	Index	Explanation
1	Connection from electric fuel pump	4	Housing
2	Anti-leak valve	5	Pressure limiting valve
3	Connection to fuel filter		

## Fuel Tank Breather System

The increased demands on the evaporative emission systems require continuous development and improvements. The F01/F02 is no different. One of the first things to notice on the fuel tank is that there is only one service port. Also, the tank is made from two pieces and joined by a plastic “welding” process.

The only items which are serviceable at this time are the fuel pump, fuel filter and pressure limiting valve. There are several breather valves installed to help the fuel tank “breathe” during refueling and during operation.

These valves are therefore divided into filler valves and service breather valves. The service breather valves have a smaller opening, which means that, during refueling, they alone would not be able to let air escape from the fuel tank fast enough.

There are service breather valves with and without over fueling protection. The service breather valves are arranged in such a way that air can still be released even if the vehicle is parked up on one side.

The filler breather valve is located at a high position. If the fuel level rises to this height during refueling, the valve closes. Air can no longer escape from the fuel tank fast enough, which causes fuel to rise up the filler pipe and switch off the fuel nozzle.

To enable the release of air to continue, there is a service breather valve located at the highest point. However, the presence of the valve in this location means that the fuel tank could be overfilled in the event of persistent refueling.

Consequently, fuel would enter the activated charcoal filter and ultimately flow back out of the opening. To prevent this, the highest service breather valve is equipped with over fueling protection like the one on the left-hand side of the vehicle (as a safeguard if the vehicle were parked up on one side). Fuel that is carried along with the release of air is collected in a fuel trap and pumped back into the surge chamber.

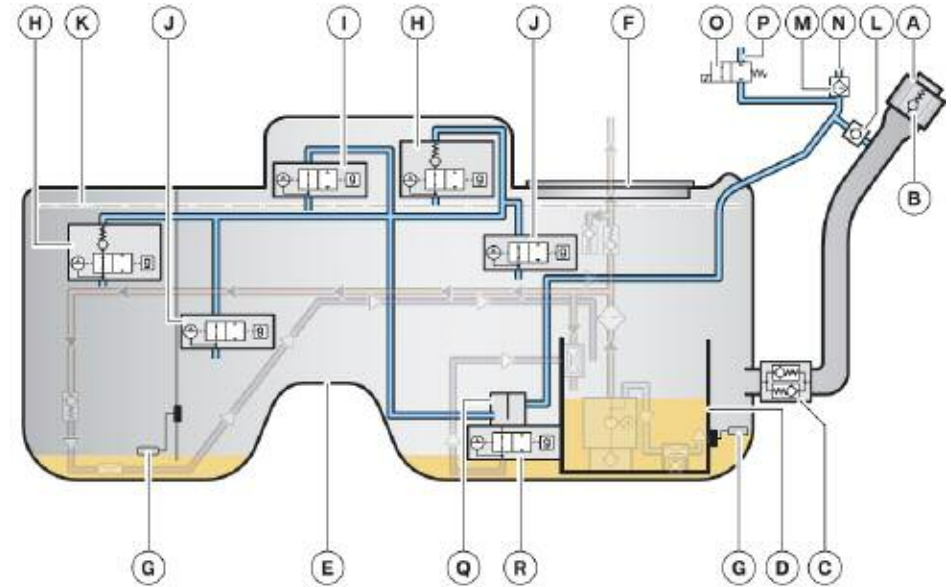

Index	Explanation	Index	Explanation
A	Fuel cap	J	Service breather valve without over fueling protection
B	Pressure relief valve	K	Maximum fill level
C	Non-return flap with pressure relief valve	L	Non-return valve
D	Surge chamber	M	Carbon canister
E	Fuel tank	N	Opening
F	Service cover	O	Fuel tank vent (purge) valve TEV
G	Lever-type sensor	P	Purge air line
H	Service breather valve with over fueling protection	Q	Fuel trap
I	Filler breather valve	R	Roll-over valve

---

NOTES

PAGE



## Workshop Exercise - F01 Fuel Systems

With the provided posters, use the magnets to complete the missing functions for the F01 fuel supply system. Complete the exercise by drawing a line from the index # to the correct purpose/function - refer to example shown.

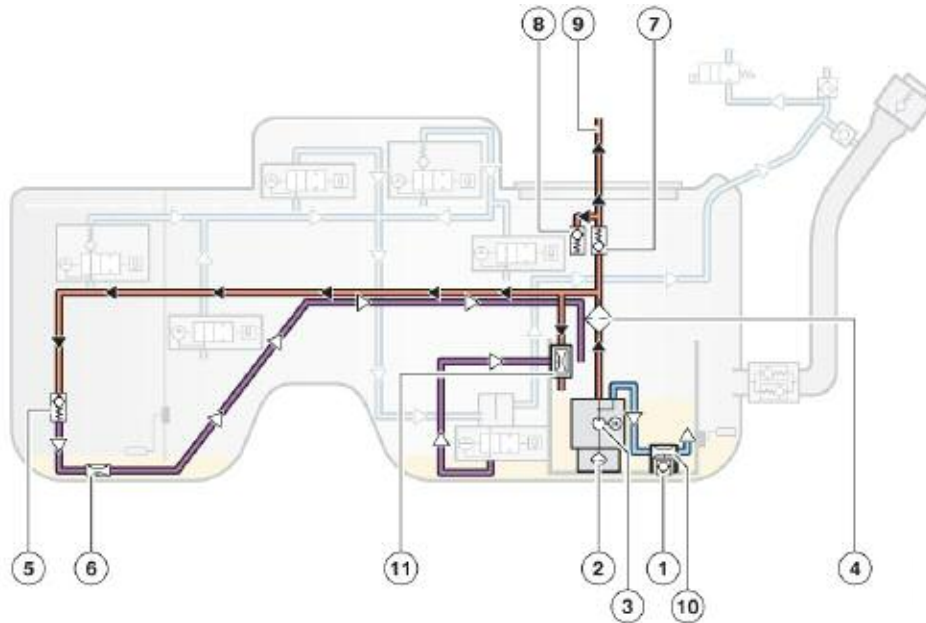

Index	Purpose/function
1	Prevents excessive pressure in fuel supply system
2	Prevents return flow of fuel from right half of fuel tank into the left half
3	Provides low pressure area to remove fuel from fuel trap
4	Protects inlet of low pressure pump from contamination
5	Provides pathway to high pressure pump
6	Maintains residual pressure in fuel supply system
7	Protects high pressure pump and fuel injectors from dirt and contamination
8	Provides low pressure area to draw fuel into surge chamber
9	Enables fuel to enter the surge chamber during refueling
10	Generates the needed fuel supply pressure
11	Provides low pressure area to keep the right side of the fuel tank at the proper level



# Workshop Exercise - F01 Fuel Tank Breather System

Using the supplied posters and training aids (fuel tank), place the letter of the correct component next to the graphics on the right in the spaces provided and match to the actual components.

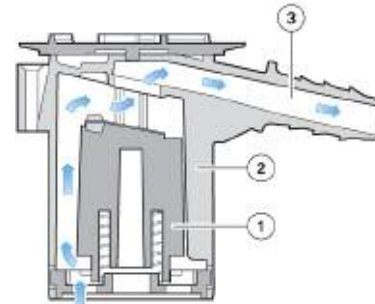
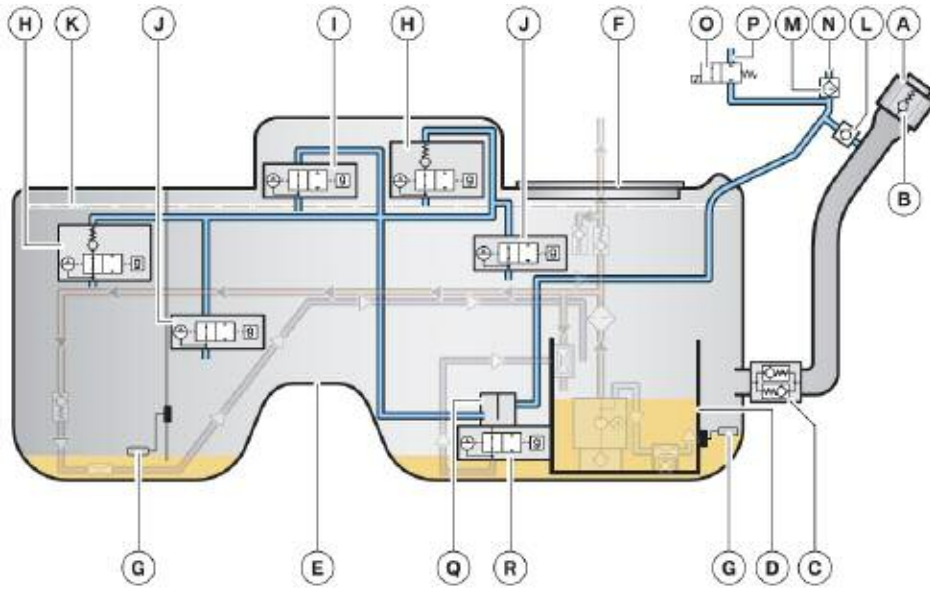

Component: \_\_\_\_\_

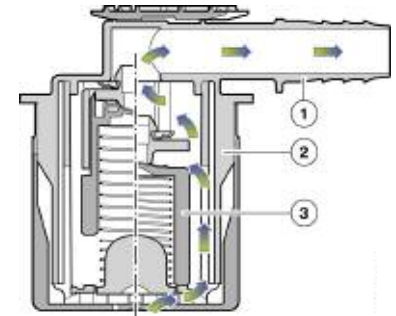

Component: \_\_\_\_\_

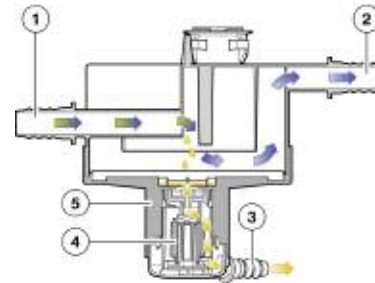

Component: \_\_\_\_\_

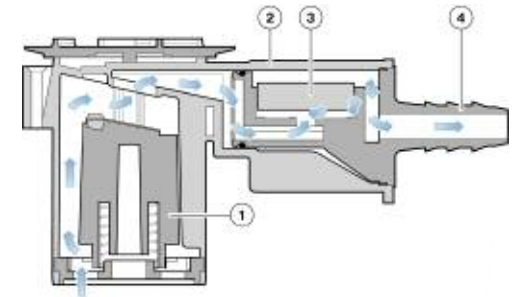

Component: \_\_\_\_\_



## Automatic Transmission

The F01/F02 is available exclusively with an automatic transmission. The transmission is the GA6HP26TU that was introduced with the E70 and was subsequently fitted in many model series since.

The F01/F02 features the already familiar electronic gearshift carried over from the E7X and E6X vehicles. The GWS is mounted on the center console which differs from the previous column mounted shifter on the E65.

### Gear Selector Switch

The gear selector switch on the F01/F02 has been carried over from the E6x and E7x. In both automatic and manual mode, operation of the switch is monostable. In other words, the selector lever always returns to its original position.



The gear selector switch also contains the control unit (GWS), which is connected to the electric gearshift controller by the PT-CAN like it was before. The second, redundant connection, is no longer connected by the LIN bus as used to be the case, but by the new PT-CAN2.

### Emergency Release

As you would expect, the F01/F02 has an emergency release for the automatic transmission. This functions in much the same way as that of the E70.

The emergency release is located under the ashtray to the front of the gear selector switch.

### Rear Axle Differential

The key aim in the development of the final drive in the F01/F02 was to make considerable savings on weight at the same time as increasing the maximum transmission capacity. The new aluminum differential offers a weight reduction of approximately 15 % compared with previous differentials.

In addition, efficiency was further improved by efforts to achieve optimum spline geometries. The result is a new generation of final drives, which are also notable for their aluminum casing.

Through the use of efficient bearings, optimum spline geometries in the oil circuit and an optimum oil volume in the differential, it was possible to reduce friction losses and churning losses and to thereby increase efficiency even further. Together with better heat dissipation, this has contributed to lower oil temperatures.

The differential for the F01/02 (750i/iL) is as follows:

- Differential type = 225AL
- Ratio = 3.462
- Weight (in kg) = 29.7

These differentials are recognizable by the letters "AL" in their designation (A = aluminum casing, L = low-friction).

## Driveshaft and Axles

The driveshaft on the F01 is made from steel and designed to meet the torque requirements of the N63 engine.

In addition to torque transfer, key aims in the designing of the driveshaft for the F01/F02 were to satisfy demands for comfort in terms of noise and vibration.

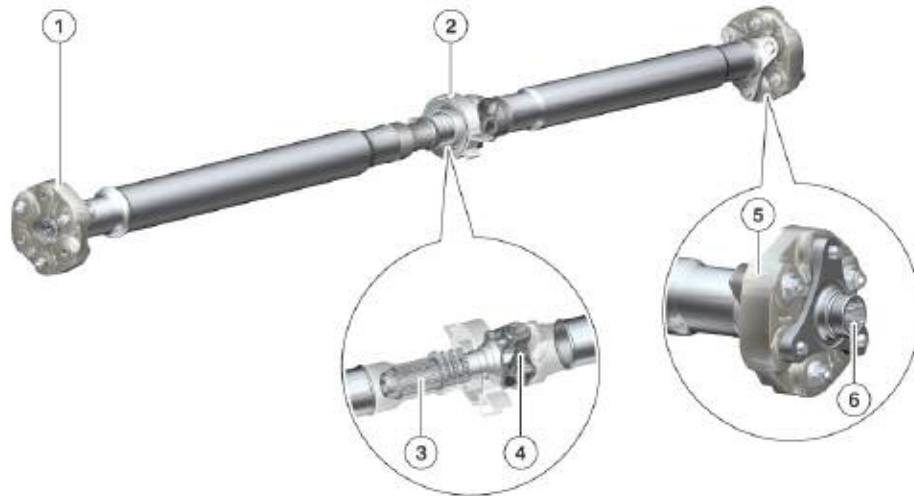

Index	Explanation	Index	Explanation
1	Flexible coupling on the automatic transmission	4	Universal joint
2	Center connection	5	Flexible coupling on rear axle differential
3	Slide piece connection	6	Push-fit connection

The joints, shaft junctions and shaft diameters were designed in such a way that no disturbance noise or vibrations at the connecting points are transmitted through the body.

On the F01/F02, the driveshaft is connected to the automatic transmission and rear axle differential exclusively by flexible couplings. This minimizes high-frequency gear tooth noise at the rear axle differential.

The connection to the automatic transmission is a screw-fitted one. At the rear axle differential end, it is push-fitted as it is on the E70. However, this is the first time that a push-fit connection with flexible coupling has been used. The center connection is a slide piece connection with universal joint.

The driveshaft absorbs some of the impact energy in the event of a head-on collision. Improvements have been made to the properties of this crash function, which is integrated into the forward driveshaft shaft tube. The compression force under which the forward driveshaft shaft tube is meant to deform has been further reduced with no effect on torque transfer capability.

Despite increased demands in terms of torque and comfort, it was possible to reduce weight by comparison with the predecessor model.

### ■ Axle Shafts

The F01/F02 has axle shafts that are push-fit at each end, i.e. wheel end and differential end. The axles shafts on the N63 engine have solid shafts.

Due to the position of the rear axle differential, the drive shafts on the left and right have a different overall length.



## Classroom Exercise - Review Questions

1. From what material is the roof panel on the F01 made and how is it attached? (Circle one statement)
  - A. The roof panel is made from steel and attached with rivets
  - B. The roof is made from carbon fiber and attached with rivets
  - C. The roof is made from aluminum and attached with rivets
  - D. The roof is made from aluminum and attached with adhesives
  
2. Circle the body panels which are made from aluminum:
 

Hood          Fenders          Trunk lid          Roof panel

Doors, front   Doors, rear   Rear quarter panels

Strut towers   Engine support
  
3. How is the ECM (DME) cooled? (circle the correct statement)
  - A. via a fan in the E-box
  - B. via liquid cooling from the charge-air cooling circuit
  - C. via liquid cooling via the main engine cooling system
  - D. via air flow from the IHKA (blower motor)
  
4. What is the maximum low side fuel pressure on the F01 (N63 engine)?
 

---



---
  
5. Which of the following components is NOT found in the fuel tank on the F01 (N63)? (circle the correct answer)
 

Fuel filter      Siphon jet      Service breather valve

Fuel pump      Fuel pressure regulator
  
6. When using ISTA for diagnosis, "Technical Data" can be found under the abbreviation: (circle one)
 

FUB   TED   STA   FTD   FEB   SIT
  
7. How does the ECM (DME) communicate to the water pump for the charge-air cooling?
 

via the BSD connection

via the LIN bus connection

via a hardwire

via the Lo-CAN bus



---

NOTES

PAGE

# Bus Systems

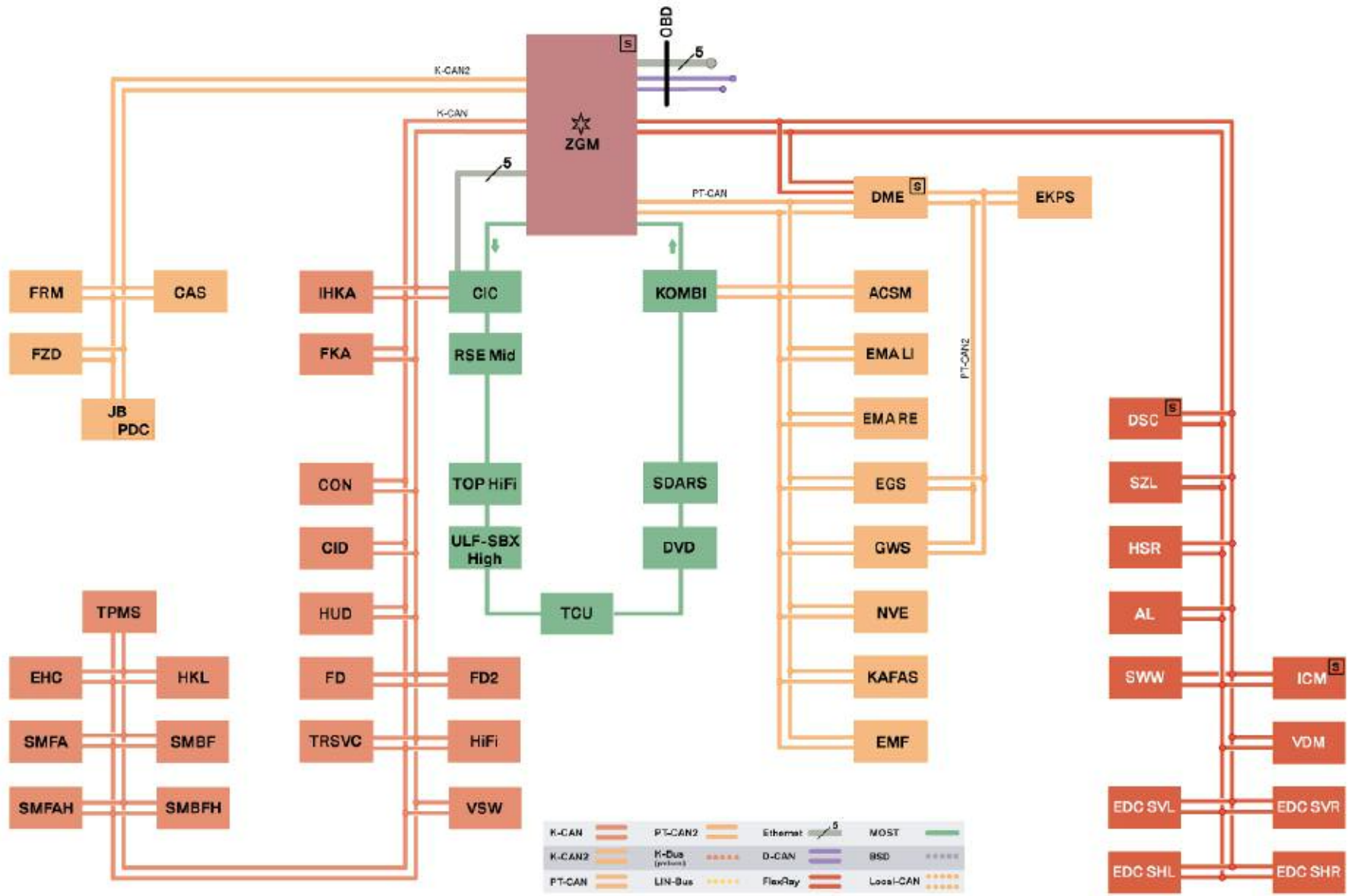

Note: FlexRay shown in “simplified” form on this bus chart.

Index	Explanation	Index	Explanation
ACSM	Advanced Crash Safety Module	EKPS	Electric Fuel Pump
AL	Active Steering	EMA LI	Electrically motorized reel, left
CAS	Car Access System (CAS 4)	EMA RE	Electrically motorized reel, right
CIC	Car Information Computer	EMF	Electromechanical Parking Brake
CID	Central Information Display	FD	Rear Display, left
CON	Controller	FD2	Rear Display 2, right
DME	Digital Motor Electronics	FKA	Rear compartment, heating/air conditioning
DSC	Dynamic Stability Control	FLA	High Beam Assistant
DVD	Digital Video Disc	FRM	Footwell Module
EDC SHL	Electronic Damping Control (Satellite rear left)	FZD	Roof Functions Center
EDC SHR	Electronic Damping Control (Satellite rear right)	GWS	Gear Selector Lever
EDC SVL	Electronic Damping Control (Satellite front left)	HiFi	HiFi Amplifier
EDC SVR	Electronic Damping Control (Satellite front right)	HKL	Trunk Lid lift
EGS	Electronic Transmission Control	HSR	Rear axle drift angle control (Rear Steering Control Module)
EHC	Electronic Height Control	HUD	Head-up Display

Index	Explanation	Index	Explanation
ICM	Integrated Chassis Management	SMFA	Seat module, driver
IHKA	Integrated Heating and Air Conditioning, automatic	SMFAH	Seat module, driver side rear
JB	Junction Box Electronics	SWW	Lane Change Warning (Active Blind Spot Detection)
KAFAS	Camera-assisted Driver Assistance Systems	SZL	Steering column switch cluster
KOMBI	Instrument Cluster	TCU	Telematics Control Unit
NVE	Night Vision Electronics	TOP-HIFI	TOP-HiFi Amplifier
PDC	Park Distance Control	TPMS	Tire Pressure Monitoring System
OBD	On Board Diagnostic Connector	TRSVC	Top Rear Side View Camera Module for rear/side view cam
RSE	Rear Seat Entertainment (Mid)	ULF-SBX High	Interface Box, high version
SDARS	Satellite Radio	VDM	Vertical Dynamics Management
SMBF	Seat module, passenger	VSW	Video Switch
SMBFH	Seat module, passenger rear	ZGM	Central Gateway Module



## Workshop Exercise - F01/02 Bus Network

*Using the supplied classroom posters, compare previous bus networks to the F01/02. To complete the exercise, answer the following questions and record your observations in the spaces provided.*

List the modules on the F01 bus network which seem new:

---

---

---

---

---

---

List the changes observed to the PT-CAN bus system:

---

---

---

---

---

---

List the changes that are observed to the FlexRay bus system:

---

---

---

---

---

---

List the changes observed to the MOST bus system:

---

---

---

---

---

---

List the changes observed to the K-CAN bus system:

---

---

---

---

---

---

List any new bus systems and any bus systems which appear to have been eliminated:

---

---

---

---

---

---



## Workshop Exercise - F01/02 Bus Network

*Using the supplied classroom posters, compare previous bus networks to the F01/02. To complete the exercise, record your observations in the spaces provided. With instructor assistance, complete the exercise by answering the indicated questions:*

What control module is the gateway for all bus systems?

---

---

What control modules contains the functions of PDC?

---

---

What control module contains the functions of Comfort Access?

---

---

What is the purpose of the Ethernet connection?

---

---

Which control module is the MOST bus master?

---

---

Which control modules have redundant PT-CAN connections (to PT-CAN 2)?

---

---

Which bus system assumes the functions of the deleted Chassis CAN (F-CAN)?

---

---

Why are the sub-bus systems not shown on the main bus chart?

---

---

What does the “s” indicate on some of the modules?

---

---

What does the “star” indicate on the ZGM?

---

---

## Overview of the Bus Systems in the F01/F02

This information contained within this workbook deals with the bus systems of the F01/F02. In addition to the following overview of bus systems, you will find a further overview of the bus systems on the fold-out pages contained within this workbook.

The fold-out page provides you with an immediate reference to the bus overview while working with the workbook.



**K-CAN 2**

### Bus Systems

The following innovations have been implemented in the bus systems in the new BMW F01/F02:

- PT-CAN with additional PT-CAN 2 (500 kBit/s)
- K-CAN with additional K-CAN 2 (500 kBits/s)
- FlexRay has been expanded and has replaced the F-CAN from previous models.
- Ethernet (fast programming access)
- LIN bus system with extended functions.

### Structure in Vehicle

With deployment of the central gateway module, the F01/F02 has a newly linked bus structure. The engine management and chassis control systems are linked across the PT-CAN (or PT-CAN 2) and the FlexRay bus system to the central gateway module (ZGM).

The control units of the general vehicle electrics are connected across the K-CAN and K-CAN 2.

The MOST is the information carrier for the majority of control units in the area of information and communication technologies.

The vehicle diagnosis communicates across the D-CAN.

The vehicle is programmed/encoded via the Ethernet access point. The sub-bus system LIN has other links. CAN - Ethernet - FlexRay - LIN - An exact description of these bus systems can be found in this workbook and the ST811 Reference Information.

### Overall Network of the F01/F02

The overall network in the F01/F02 consists of various bus systems that enable communication between the individual control units. In view of the increasing interconnection of the control units, it is possible to use the sensors of one system throughout the network.

The sensors are connected to the control unit that initially requires the information logic-based and virtually in real time. This information, however, can also be made available to other control units.

Using the example of the vertical dynamics management (VDM), initially, the VDM control unit picks up the ride-height levels of the wheels using height-level sensors. The automatic headlight vertical aim control can also use this information for the purpose of adapting the beam throw of the headlights.

The VDM makes available the information via the corresponding bus systems (VDM - FlexRay - ZGM - K-CAN 2 - FRM) to the footwell module.

Apart from the Ethernet, all bus systems in the F01/F02 are already known from other BMW models. This section provides an overview of all bus systems of the F01/F02.

This workbook contains a detailed description of the Ethernet system, of the FlexRay bus and of the LIN bus sub-bus system.

### Overview of Bus Systems

In principle, a distinction is made between two groups of bus systems:

- Main bus systems: Ethernet, FlexRay, KCAN, K-CAN 2, MOST, PT-CAN and PTCAN 2
- Sub-bus systems: BSD, D-CAN (diagnosis on CAN), LIN, Local-CAN.

Main-bus systems are responsible for the data exchange between the ECUs throughout the vehicle system. This includes system functions such as diagnosis, programming and encoding.

Sub-bus systems exchange data within one function group.

For example, the data of the rain-light-solar-condensation sensor are read in by the junction box electronics, processed and forwarded to the wiper module.

The connection between the control units of the rain-light-solar-condensation sensor and junction box electronics is a sub-bus and designed as a LIN bus.

### Main Bus Systems

Main Bus System	Data rate	Bus topology
D-CAN	500 kBits/sec	Linear, 2 wire
Ethernet	100 Mbits/second	Linear
FlexRay	10 Mbits/second	Mixed topology, 2 wire
K-CAN	100 kBits/second	Linear, 2 wire, single wire mode possible for emergency operation
K-CAN 2	500 kBits/second	Linear, 2 wire
MOST	22.5 Mbits/second	Ring, fiber optic
PT-CAN (chassis)	500 kBits/second	Linear, 2 wire
PT-CAN 2 (powertrain)	500 kBits/second	Linear, 2 wire

The main bus systems are responsible for cross-system data exchange.

#### ■ Changes to Main Bus Systems

The most important changes to the changes systems in the F01/F02 are:

- Ethernet - fast vehicle programming access
- Powering up certain bus systems also possible without wake-up line (now KCAN 2).

The central gateway module interlinks all the main bus systems.

## Diagnosis Can (D-CAN)

The F01/F02 will continue will the D-CAN for diagnostic communication. In order for the F01 to communicate with the latest BMW diagnostic equipment, the ICOM A must be used.

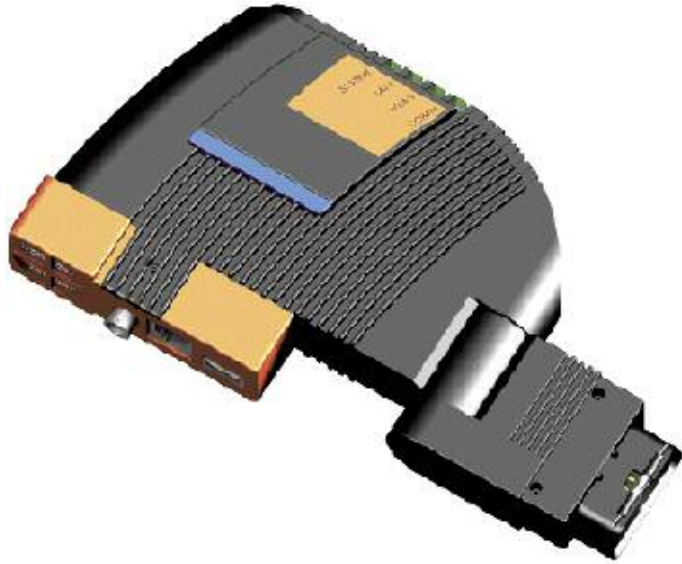

In addition, the D-CAN on the F01 uses a pair of terminal resistors on the D-CAN circuit. One is located in the ZGM, the other is located in the wiring harness between the diagnostic connector (OBD II) and ZGM.

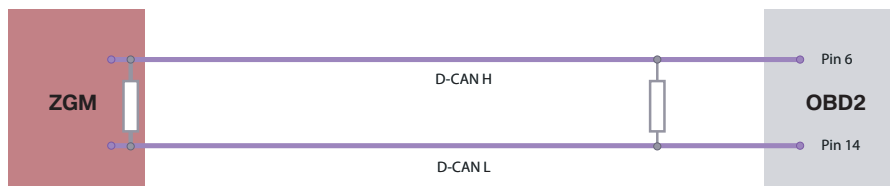

Diagnostic access, F01/F02

The diagnosis socket is located under the dashboard on the driver's side. The ICOM A is used as the interface to the BMW diagnosis system.

On board access (OBD) in the vehicle will remain unchanged. The pin assignments are as follows:

- 16 = Terminal 30
- 5 = Terminal 31
- 14 + 6 = Communication connections
- 3, 11, 12, 13 = Ethernet connections.
- 8 = activation of Ethernet.

## Location of D-CAN Connection

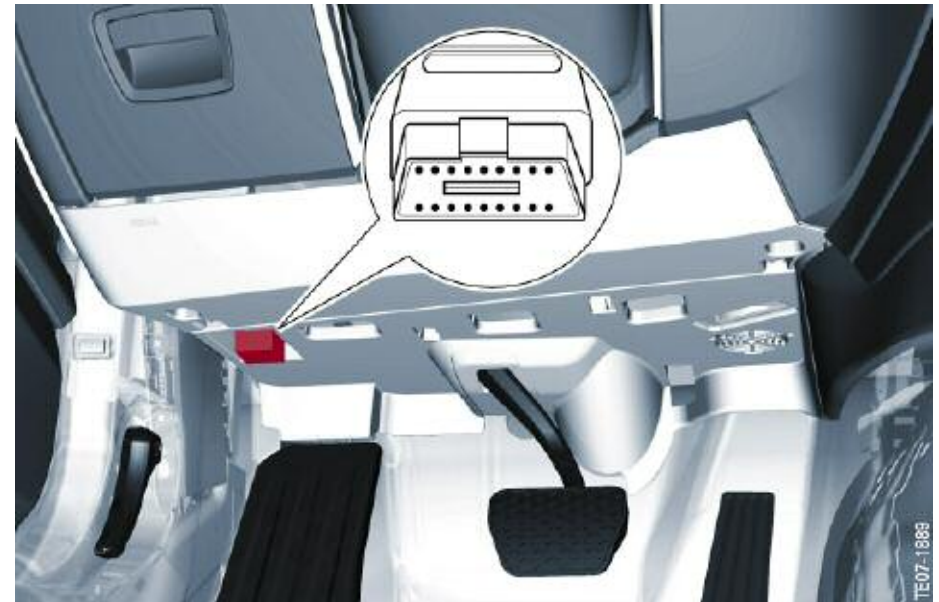



## K-CAN

The bus systems used to date are also used in the F01/F02.

The K-CAN is responsible for communication of the components with a low data transfer rate. The K-CAN is also connected to the other bus systems via the central gateway module.

The K-CAN is set up as line topology. Some control units in the K-CAN have a LIN bus as sub-bus. The K-CAN has a data transfer rate of 100 kBit/s and is designed as a twisted pair of wires.

The K-CAN has the possibility to be operated as a single-wire bus in the event of a fault.

The K-CAN control unit is wakened via the bus, without an additional wake-up line.

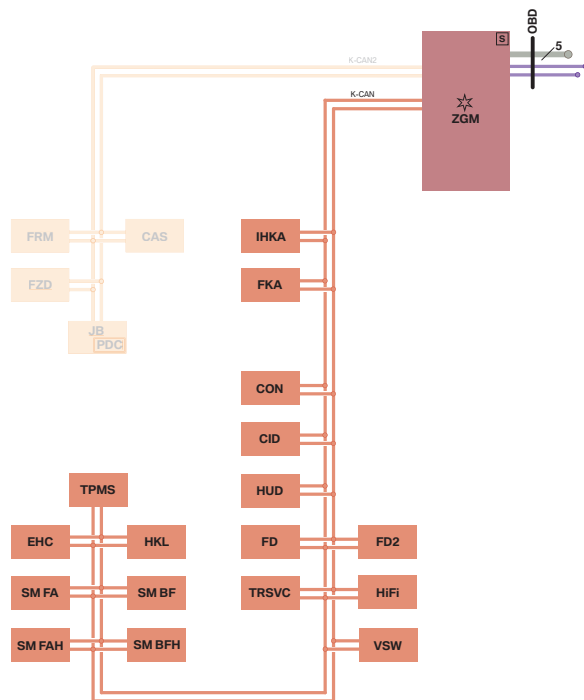

## K-CAN 2

The K-CAN 2 is responsible for communication of the control units with a high data transfer rate. The K-CAN 2 is also connected to the other bus systems via the central gateway module (ZGM). A LIN-Bus as a sub-bus is connected to all control units in the K-CAN 2. The K-CAN 2 can be wakened via any of these sub-busses, without an additional (hardwire) wake-up line. This is represented by the “wake authorized” symbol  next to all of the control units of K-CAN 2 on the Bus Overview. (See bus chart below).

To provide a rapid start enable, the CAS has an additional redundant bus connection to the DME. On this CAS bus, the data are transferred per K bus protocol.

The K-CAN 2 has a data transfer rate of 500 kBit/s and is designed as a twisted pair of wires.

There are 2 terminal resistors on K-CAN 2 are located in the ZGM and JB electronics.

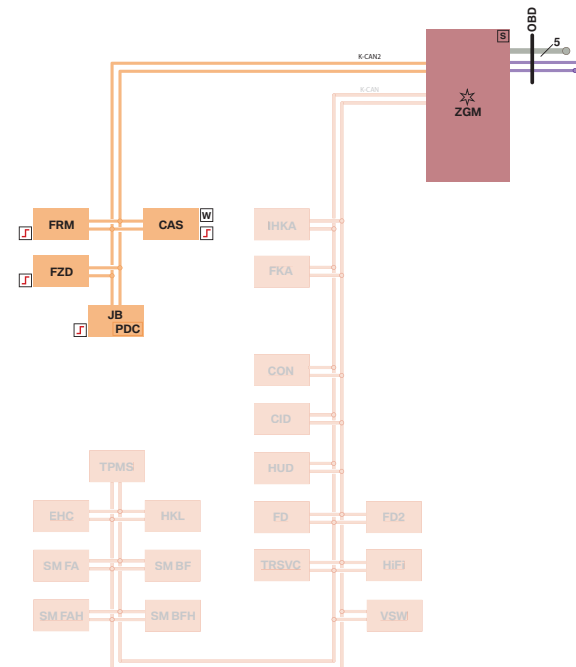

## PT-CAN

The PT-CAN connects the engine management system to the gearbox control, but now also interconnects systems in the area of safety and driver assistance systems.

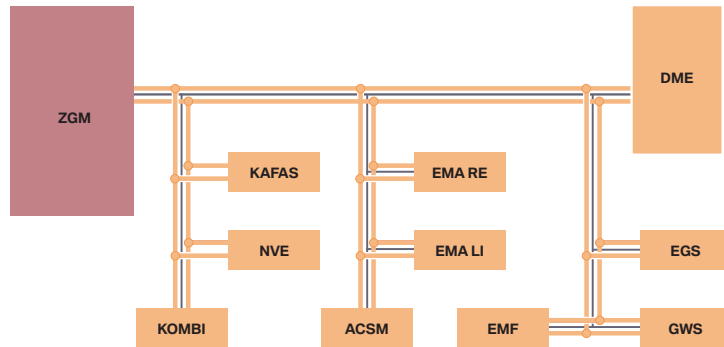

It is line-based with tap lines to the individual systems. The PT-CAN has a data transfer rate of 500 kBit/s and is designed as a twisted pair of wires. Control units with a power supply via terminal 30 have an additional wake-up line (see illustration).

The terminal resistors in the PT-CAN are located in the following control units:

- Instrument cluster (Kombi)
- Electromechanical parking brake (EMF)

## PT-CAN 2

The PT-CAN 2 forms a redundancy for the PT-CAN in the area of the engine management system and also transfers signals to the fuel pump control.

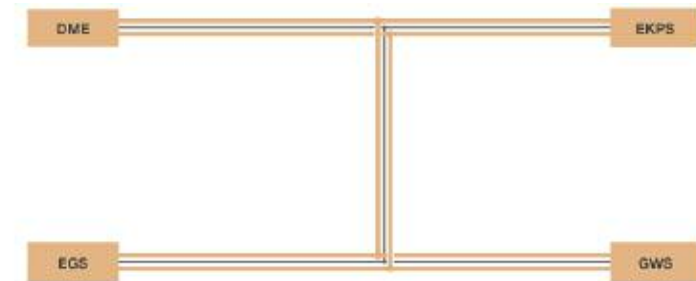

The PT-CAN 2 has a data transfer rate of 500 kBit/s and is designed as a twisted pair of wires with an additional wake-up line.

The terminal resistors in the PT-CAN 2 are located in the following control units:

- Digital Motor Electronics (DME)
- Control unit for electric fuel pump (EKPS).

## Ethernet

Ethernet is a manufacturer-neutral, cable bound network technology. Most computer networks nowadays are based on this data transfer technology.

The so-called Ethernet was developed more than 30 years ago. Since then, the data transfer rates have multiplied. The Ethernet in the F01 has a data transfer rate of 100 MBit/s.

### Application in the F01/F02

The Ethernet in the diagnosis socket is only enabled when the BMW programming system (ICOM A) is connected. There is an activation bridge in the programming connector, between pins 8 and 16. This switches the power supply for the Ethernet controller in the central gateway module.

This means that Ethernet access to the central gateway module is disabled while the vehicle is being driven by the customer.

### Security

Each participant in an Ethernet has an individually assigned ID number, a MAC address (Media Access Control). This address and the VIN (Vehicle Identification Number) identifies the vehicle to the BMW programming system on connection setup. This prevents changes to the data records and stored values by third parties.

In the same way as in a computer network in the office, each device in a network must receive unique identification. This is why the central gateway module is assigned a so-called IP address by the programming system after connection setup.

The function of an IP address in a network corresponds to that of a telephone number in the telephone network. This IP address is assigned per DHCP (Dynamic Host Configuration Protocol).

This is a method of automatic allocation for IP addresses to user devices in a network.

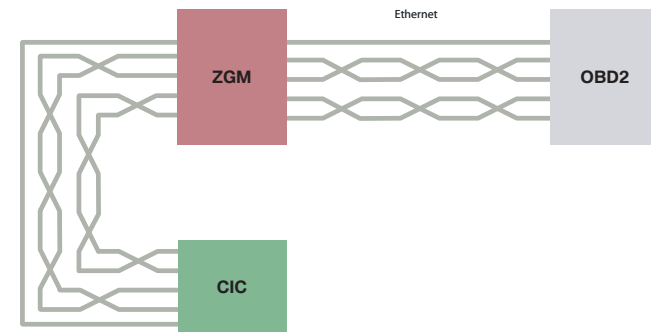

### Features of Ethernet

- Very high data rate of 100 MBit/s
- System start time with connection setup and address assignment under three seconds, sleeping under one second
- System access only via BMW programming systems.

### Functions of Ethernet

- Faster programming of the vehicle in Service
- Transmission of media data between ZGM and CIC

The wiring between the diagnosis socket and ZGM is with two pairs of wires without additional shielding. There is also an activating line that supplies the Ethernet controllers in the control units with voltage.

## FlexRay - Application in the F01/F02

In the F01/F02, the FlexRay bus system is being used for the first time across systems to network dynamic driving control systems and the engine management system in a series vehicle.

The central gateway module sets up the link between the various bus systems and the FlexRay.

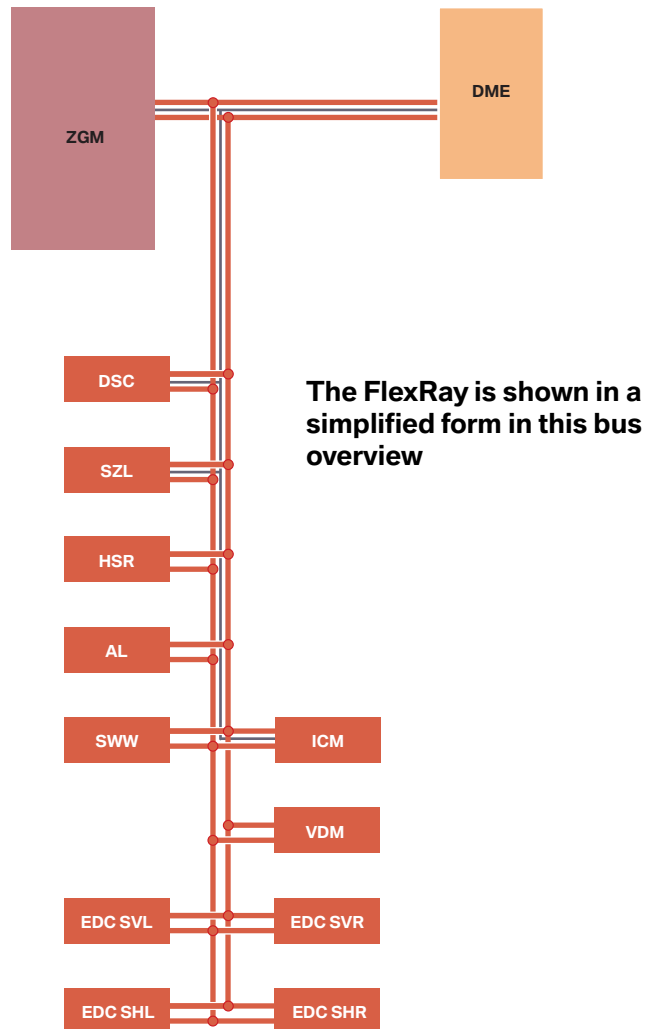

## FlexRay Bus Topology on the F01

The FlexRay is shown in a simplified form in the overview of the bus systems. The actual topology is shown in the illustration.

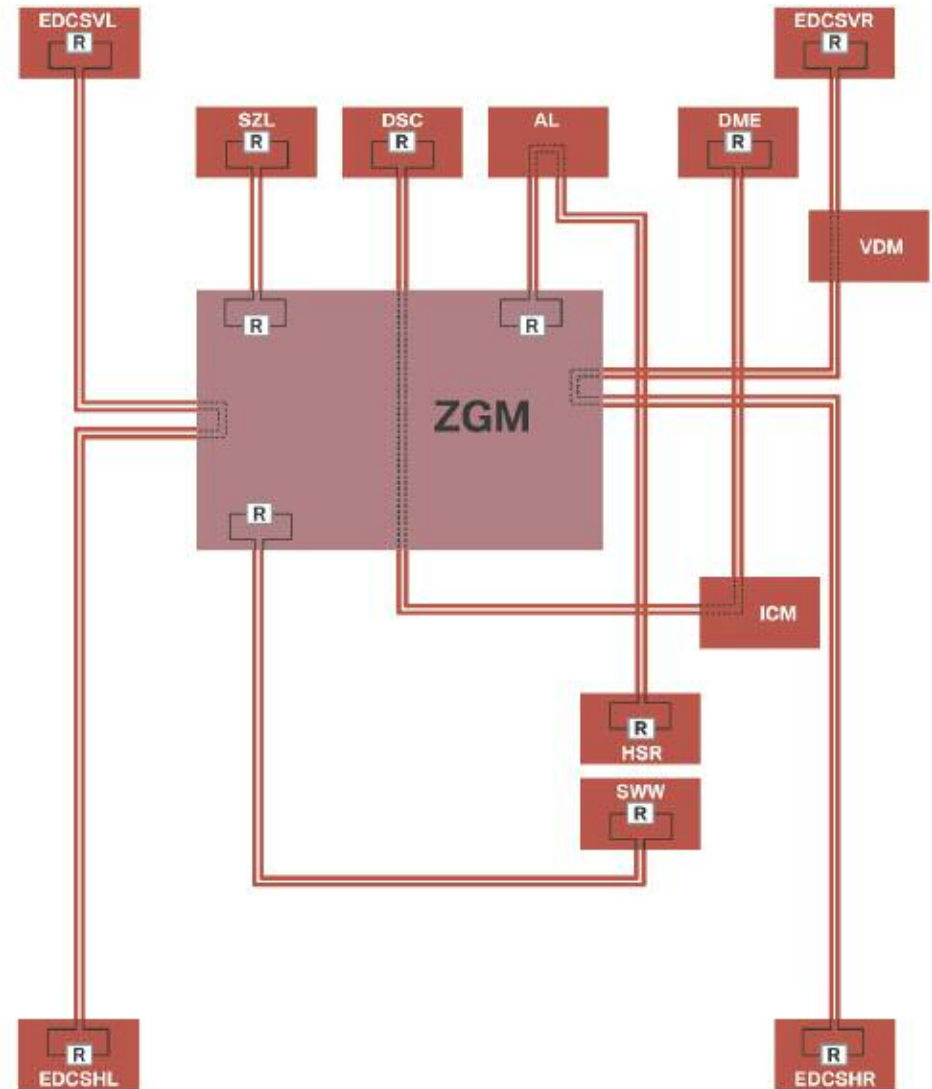

The ZGM contains two so-called star couplers, each with four bus drivers. The bus drivers forward the data of the control units via the communication controller to the central gateway module (ZGM). Depending on the type of termination the FlexRay control units have, they are connected to these bus drivers in two different ways.

### Bus Termination

In the same way as most bus systems, resistors for termination (as bus termination) are also used at both ends of the data lines on the FlexRay to prevent reflections on the lines.

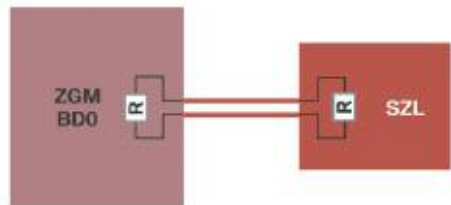

The value of these terminal resistors is determined from the data transfer rate and cable lengths. The terminal resistors are located in the control units.

If only one control unit is connected to a bus driver (e.g. SZL to the bus driver BD0), the connections on the bus driver and on the control unit are fitted with a terminal resistor. This type of connection at the central gateway module is called "end node termination".

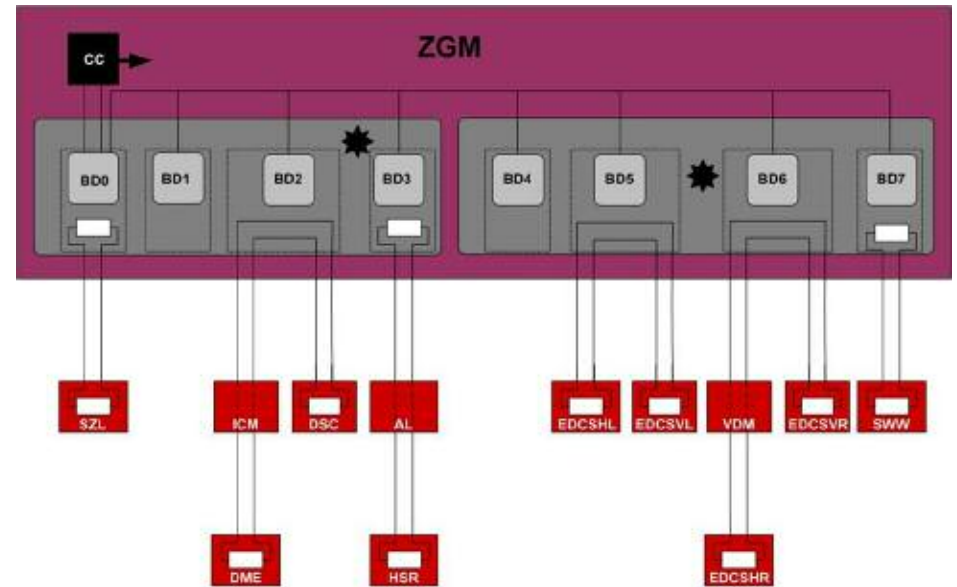
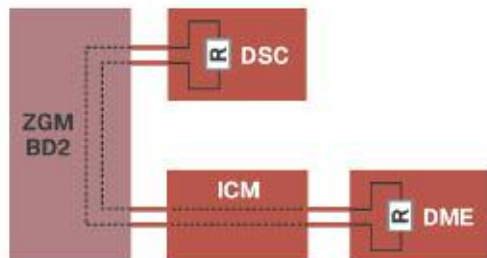

If the connection at the control unit is not the physical finish node (e.g. DSC, ICM and DME at the bus driver BD2), it is referred to as a FlexRay transmission and forwarding line. In this case, both of the components must be terminated at the ends of each bus path with terminal resistors.

This connection option exists for the central gateway module and a number of control units. However, the control unit with a transmission and forwarding line has a 'non end node termination' for data pickup. This type of termination cannot be tested using measurement systems at the control unit connector due to its resistor / capacitor circuit. To measure the (current-free) FlexRay bus to determine the line or terminating resistance, please be sure to use the vehicle wiring diagram.

## ■ Wiring

The wiring of the FlexRay bus in the F01/F02 is executed as a sheathed, two-wire, twisted cable. The sheathing protects the wires from mechanical damage.

Some of the terminal resistors are located in the central gateway module and in the user devices. Since the surge impedance (impedance of high frequency lines) of the lines depends on external influencing factors, the terminating resistors are precisely matched to the required resistance.

The sections of line to the user devices can be checked relatively easily by means of a resistance measuring instrument (ohmmeter, multimeter). The resistance should be measured from the central gateway module. Pin assignment, see 'BMW diagnostic system'.

The terminal resistors in the FlexRay are located in the control units:

- Central gateway module (ZGM)
- Electronic Damper Control satellites. (EDC\_All)
- Digital Motor Electronics (DME)
- Dynamic Stability Control (DSC)
- Rear-axle drift angle control (HSR)
- Steering column switch cluster (SZL)
- Lane change warning (SWW).

## Measurements on the FlexRay

For resistance measurement in the FlexRay, be sure to observe the vehicle wiring diagram! The various termination options mean that misinterpretations of the measurement results can occur.

Measuring the resistance of the FlexRay lines cannot provide a 100% deduction in terms of the system wiring. In the case of damage such as pinching or connector corrosion, the resistance value may be within the tolerance when the system is static.

In dynamic mode, however, electrical influences can cause increased surge resistance, resulting in data transmission problems.

It is possible to repair the FlexRay bus. If damaged, the cables can be connected using conventional cable connectors. Special requirements, however, must be observed when reinstalling the system.

The wiring of the FlexRay system consists of twisted lines. Where possible, this twisting should not be altered during repairs. Repaired areas with stripped insulation must be sealed again with shrink-fit tubing. Moisture can affect the surge resistance and therefore the efficiency of the bus system.

## ■ Wake-up and Sleep Characteristics

Although the FlexRay control units can be wakened per bus signal, most FlexRay control units are activated across an additional wake-up line by the CAS. The wake-up line has the same function as the previous wake-up line (15WUP) in the PT-CAN.

The signal curve corresponds to the signal curve of the PT-CAN. The active steering and the VDM are not wakened via the wake-up cable, rather per bus signal. The four damper satellites are then activated directly by the VDM by switching the power supply.

## MOST Bus

On the F01/F02, the MOST bus is, for the most part, identical to previous models with regard to operation and function. There are some changes unique to these models which are outlined below.

### The MOST Control Units and Light Direction

In the F01/F02, the MOST bus is used for the components in information/communication systems. The CIC is used as the master control unit.

Other bus users may be:

- DVD changer
- Instrument cluster
- Top-HiFi amplifier
- Satellite tuner SDARS (only US version)
- Telephone.
- Rear Seat Entertainment
- ULF-SBX high

The MOST programming access used in models to date is no longer required for the F01/F02. The programming now takes place on these vehicles via the Ethernet access point.

### ■ Light Direction

Data are always sent in one direction on the MOST bus. Each control unit can send data on the MOST bus.

The physical light direction runs from the master control unit (Car Information Computer) to the DVD changer, to the instrument cluster, to the ZGM (Central Gateway Module) and from there to the fiber optic cable distributor/connector. All the control units fitted in the rear end are connected at the fiber optic cable distributor. From the last control unit, the light returns to the master control unit.

The following overview shows one of the possible equipment configurations.

### Schematic view of control modules on the MOST Bus

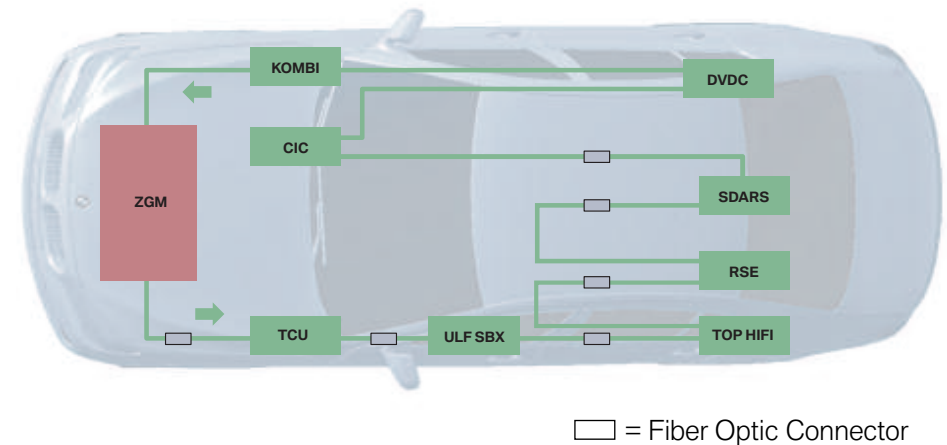

### ■ Fiber Optic Connector

The use of the fiber optic connector provides the advantage of being able to easily retrofit control units in the area of the luggage compartment.

The fiber optic cable connector is located in the luggage compartment of the F01/F02, to the left behind the side wall trim. The fiber optic cable connector is arranged in the MOST bus system between the front area of the vehicle (head unit, DVD changer) and the rear area of the vehicle (TCU, SBX etc.).

Two fiber optic connectors are installed in the F01. One is responsible for the factory installed control units. The other is used for the preparations for options.

## Sub-bus Systems

Sub-bus systems exchange data within the system. These systems are used to exchange relatively small quantities of data in specific systems.

Sub-bus	Explanation	Index
BSD	9.6 kBits/s	Linear, single wire
LIN	9.6/19.2/20.0 kBits	Linear, single wire
LoCAN	500 kBits/s	Linear, two wire

### BSD

The bit-serial data interface BSD is also used on the F01/F02 (due to lack of available interfaces). It makes the following connections from the engine management to the corresponding sub systems:

- Alternator regulator
- Oil condition sensor

### K-bus Protocol

The term "K-bus (protocol)" is used for a series of sub-bus systems in the bus overview. These sub-bus systems are used for various purposes. The K-bus protocol used here is a common component already used in predecessor models. The protocol is used, e.g. on the following systems:

- Connection between ACSM and TCU
- Comfort Access
- CAS bus

### Local CAN

The Local-CAN serves to transfer the high data volumes of the following sensors to the ICM.

- Short-range and long range radar sensors to the ICM.

The Local-CAN has a data transfer rate of 500 kBit/s and is designed as a twisted pair of wires.

The terminal resistors in the Local-CAN are located in the ICM and the long range radar sensor:

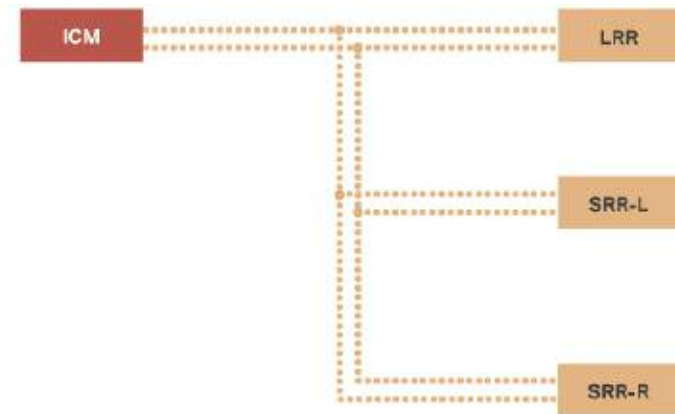

### LIN bus

The LIN bus has been used as early as the E60 and was also used to control the outside mirrors on the E46. Mainly, the versions V2.0 or higher are used in the F01/F02. For the F01/F02, various connections per LIN bus are implemented:

- E.g.: Footwell module to driver's door switch cluster
- Connection from footwell module to the outside mirrors
- Connection from roof functions center to rain-light-solar-condensation sensor
- Activation of the 16 IHKA actuator motors per "daisy chain" assignment (series connection of the signal lines).



Due to the lower data rate on the LIN bus, terminal resistors are not used.

In the F01/F02, the following control units still correspond to the V1.x specification:

- Belt hand-over
- Outside mirror
- Blower output stages
- Intelligent Battery Sensor

### **LIN V2.0 (or V2.1)**

LIN components that correspond to the specification of data protocol LIN V2.0 or higher have extended functions.

- The LIN components for V2.x are delivered with a device ID and a base configuration. The final (dynamic) configuration and the allocation of the ID number take place on commissioning by the master control unit.

If one of these components is replaced, this operation must be initiated manually by means of the BMW diagnosis system.

- The data protocol has become more variable, permitting, if required, periodic alongside sporadic messages as of specification V2.0. These "sporadic frames" are only sent if the master control unit requires data from the secondary control units or outputs data. Without such a request, the time slots in the messages remain empty.
- The master control units can send so-called multiple requests to secondary control unit groups. To reduce the bus load, the contacted secondary control units only respond in the case of changed values (e.g. door contact).

All master control units of the LIN V2.x specification are downwardly compatible to (secondary control units) components of previous specifications.

However, all V2.0 secondary control units also require a V2.x master controller.

A number of the connected components are only diagnosis-capable to a limited degree, for example the rain-light-solar-condensation sensor.

In this case, the master control unit serves as the gateway to the remaining bus system. The diagnosis requests from the ZGM or BMW diagnosis system are inserted in the sporadic section of a LIN frame.

A special feature in the F01/F02 is that the data communication between the Comfort Access and diversity antenna is implemented with 20.0 kBit/s due to the large number of small data packages.

The slightly higher transfer rate means that the time slots in the data protocol can be better exploited. The master control unit sends the "sleep command" to place the LIN in the idle state.

The "sleep command" can also be sent with terminal R "On", e.g. for mirror adjustment. The "wake-up command" can also be sent by a secondary control unit.

The LIN messages in the data protocol are divided into four sections:

- Synchronization
- Identifier
- Data
- Checksum

## LIN Bus Overview

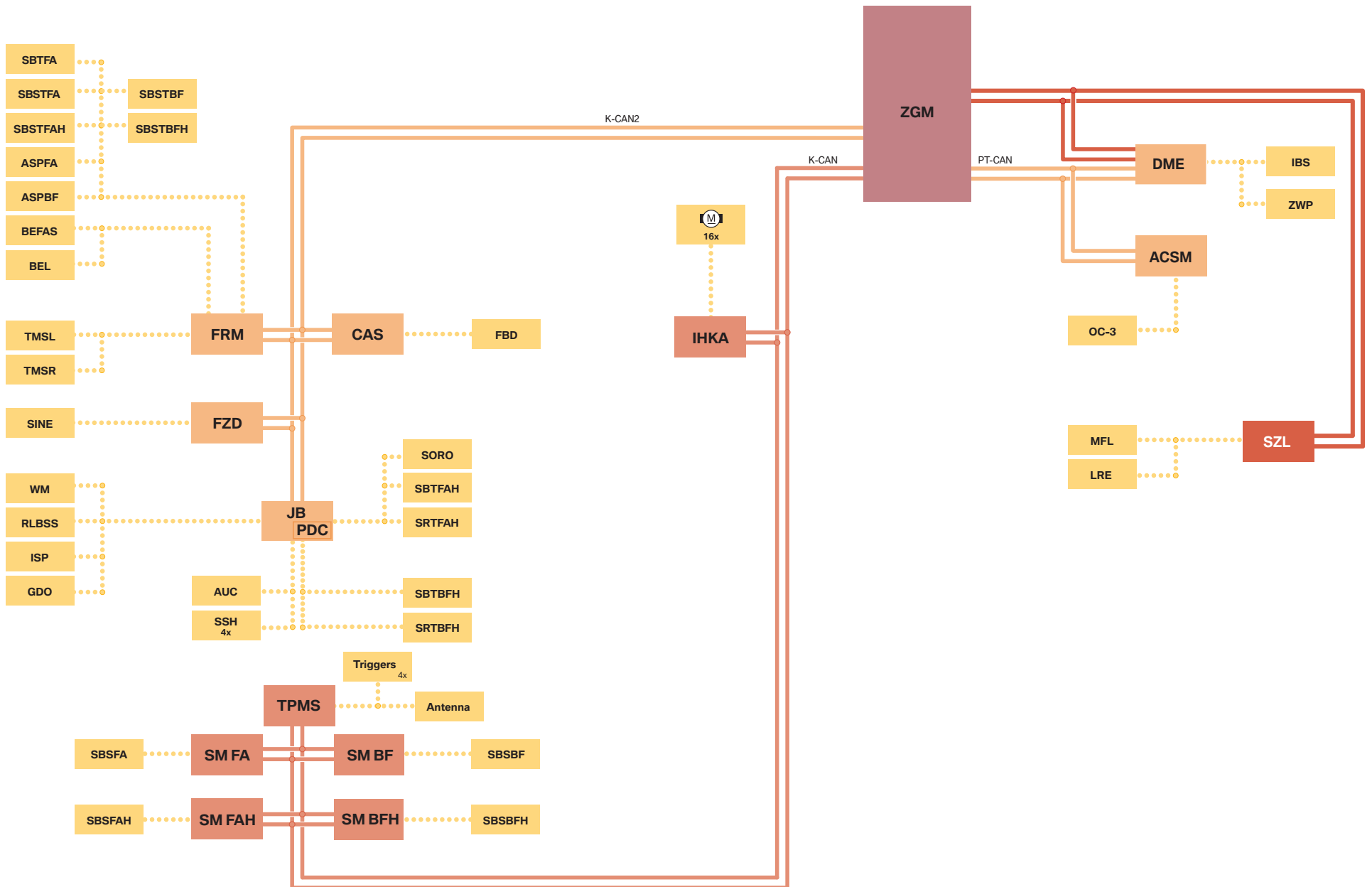

Index	Explanation
ACSM	Advanced Crash Safety Module
ASPBF	Outside mirror, passenger
ASPFA	Outside mirror, driver
AUC	Automatic recirculated air control
BEFAS	Driver assistance systems operating unit
BEL	Light operating unit
CAS	Car Access System
DME	Digital Motor Electronics
FBD	Remote Control Services
FRM	Footwell Module
FZD	Roof Functions Center
GDO	Garage door opener
IBS	Intelligent Battery Sensor
IHKA	Integrated Heating and Air Conditioning, automatic
ISP	Interior Mirror
JB	Junction Box Electronics
LRE	Steering Wheel Electronics
MFL	Multi-function Steering Wheel
OC-3	Seat Occupancy Detection, front passenger
PDC	Park Distance Control
RLSBS	Rain-light-solar-condensation sensor
SBSBF	Switch block for seat adjustment, passenger
SBSBFH	Switch block for seat adjustment, passenger's side rear
SBSFA	Switch block for seat adjustment, driver

Index	Explanation
SBSFAH	Switch block for seat adjustment, driver's side rear
SBSTBF	Switch block for seat memory, passenger
SBSTBFH	Switch block for seat memory, passenger's side rear
SBSTFA	Switch block for seat memory, driver
SBSTFAH	Switch block for seat memory, driver's side rear
SBTBFH	Switch block for windows, passenger's side rear
SBTFA	Switch block for windows, driver
SBTFAH	Switch block for windows, driver's side rear
SINE	Alarm Siren
SMBF	Seat Module, passenger
SMBFH	Seat Module, passenger's side rear
SMFA	Seat Module, driver
SMFAH	Seat Module, driver's side rear
SORO	Roller sunblind
SRTBFH	Roller sunblind switch, passenger's side rear
SRTFAH	Roller sunblind switch, driver's side rear
SSH	Seat heating switch
SZL	Steering column switch cluster
TMSL	Headlight module, left
TMSR	Headlight module, right
TPMS	Tire Pressure Monitoring System
WM	Wiper Motor/module
ZGM	Central Gateway Module
ZWP	Auxiliary water pump



## Workshop Exercise - F01 Bus Systems and Terminal Resistors (PT-CAN 2)

Using an instructor designated vehicle and training aids, locate the terminal resistors for PT-CAN 2. Use ISTA to locate the connections. Complete the exercise by filling in the requested information and answering the pertinent questions:

Using the illustration below, circle the control modules which contain the terminal resistors for PT-CAN 2:

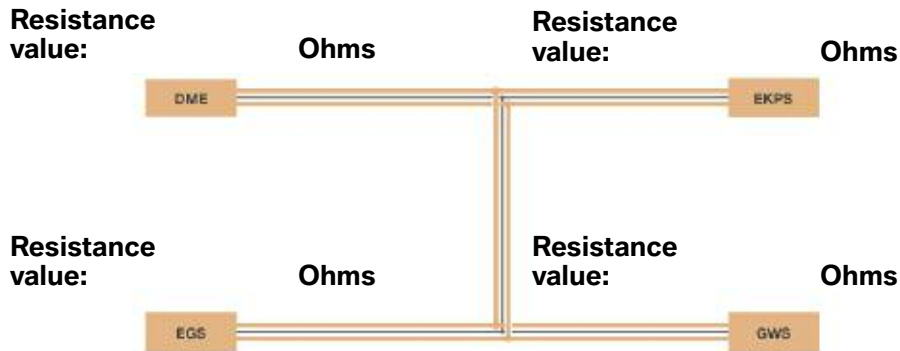

Using the appropriate test cables, measure the individual resistance values of the individual components and write into the spaces provided above:

What should be the result, when checking the total parallel resistance of the PT-CAN 2 circuit?

---



---

What is your **actual** result when testing the total parallel resistance of the PT-CAN 2 circuit?

---



---

Record the PT-CAN 2 connections to the following components for future reference:

Place a "W" next to those modules which are "wake capable":

Module	Wake Capable (KL15 wake-up)	Connector #	PT-CAN 2 (high)	PT-CAN 2 (low)
DME			pin:	pin:
EKPS			pin:	pin:
EGS			pin:	pin:
GWS			pin:	pin:

Which modules on PT-CAN 2 are also "wake authorized"?

---



---



---



---

What are the part numbers of the test cable used?

---



---



---



---



## Workshop Exercise - F01 Bus Systems and Terminal Resistors (PT-CAN)

Using an instructor designated vehicle and training aids, locate the terminal resistors for PT-CAN. Use ISTA to locate the connections. Complete the exercise by filling in the requested information and answering the pertinent questions:

Using the illustration below, circle the control modules which contain the terminal resistors for PT-CAN:

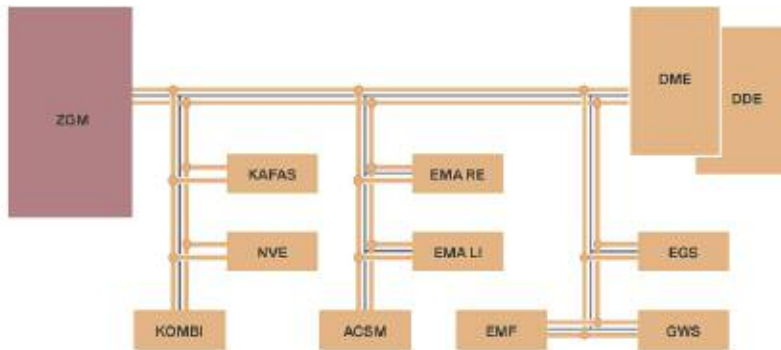

Using the appropriate test cables, measure the individual resistance values of the individual components and write into the spaces provided:

What should be the result, when checking the total parallel resistance of the PT-CAN circuit?

---



---

What is your **actual** result when testing the total parallel resistance of the PT-CAN circuit?

---



---

Record the PT-CAN connections to the following components for future reference:

Place a "W" next to those modules which are "wake capable":

Module	Wake Capable (KL15 wake-up)	Connector #	PT-CAN (high)	PT-CAN (low)
DME			pin:	pin:
EGS			pin:	pin:
GWS			pin:	pin:
KOMBI			pin:	pin:
NVE			pin:	pin:
ZGM			pin:	pin:
KAFAS			pin:	pin:
EMA RE			pin:	pin:
EMA LI			pin:	pin:
ACSM			pin:	pin:
EMF			pin:	pin:

Which modules on PT-CAN are also "wake authorized"?

---

What are the part numbers of the test cable used?

---



---



## Workshop Exercise - F01 Bus Systems and Terminal Resistors

Using an instructor designated vehicle and training aids, locate the terminal resistors for FlexRay. Use ISTA to locate the connections. Complete the exercise by filling in the requested information and answering the pertinent questions:

Using the illustration below as a guide, locate the values for the the terminal resistors on the FlexRay bus system:

Using the appropriate test cables, measure the individual resistance values of the individual components and write into the spaces provided:

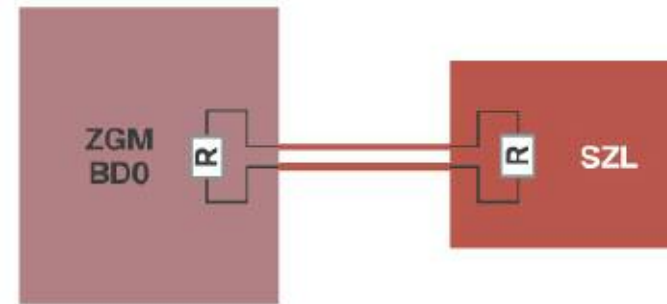
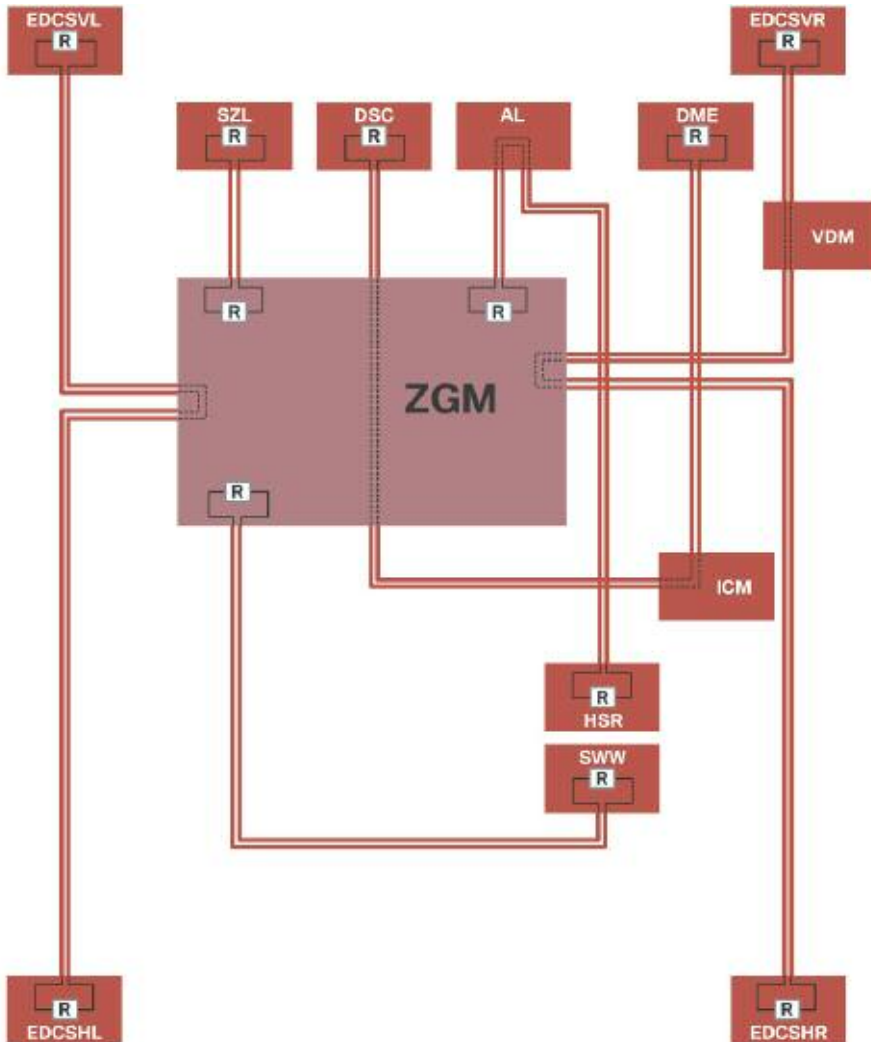

Module	Terminal Resistor Value	Connector #	FlexRay (BP)	FlexRay (BM)
ZGM			pin:	pin:
SZL			pin:	pin:

What should be the result, when checking the total parallel resistance of the FlexRay circuit between ZGM and SZL?

What is your **actual** result when testing the total parallel resistance of the FlexRay circuit between ZGM and SZL?

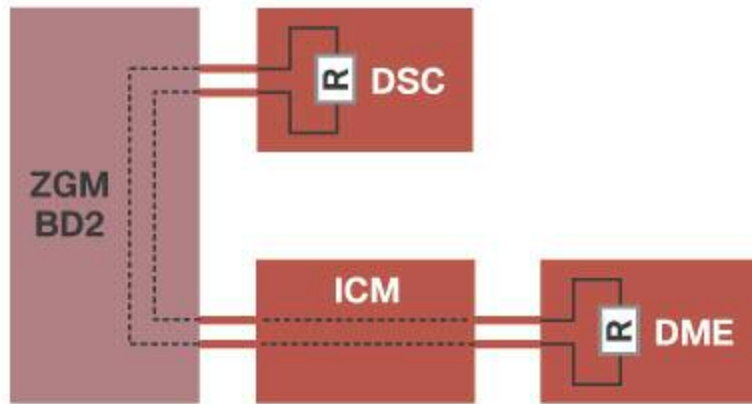

Module	Terminal Resistor Value	Connector #	FlexRay (BP)	FlexRay (BM)
DSC to ZGM			pin:	pin:
ZGM to DSC			pin:	pin:
ZGM to ICM			pin:	pin:
ICM to ZGM			pin:	pin:
ICM to DME			pin:	pin:
DME to ICM			pin:	pin:

What should be the result, when checking the total parallel resistance of the FlexRay circuit between DSC and DME?

---

What is your **actual** result when testing the total parallel resistance of the FlexRay circuit between DSC and DME?

---

What is the measured resistance of the FlexRay connections through the ICM and ZGM?

---

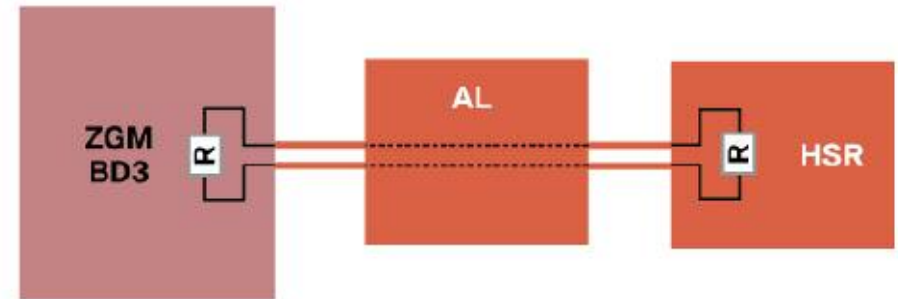

Module	Terminal Resistor Value	Connector #	FlexRay (BP)	FlexRay (BM)
ZGM to AL			pin:	pin:
AL to ZGM			pin:	pin:
AL to HSR			pin:	pin:
HSR to AL			pin:	pin:

What should be the result, when checking the total parallel resistance of the FlexRay circuit between ZGM and HSR?

---

What is your **actual** result when testing the total parallel resistance of the FlexRay circuit between ZGM and HSR?

---

What is the measured resistance of the FlexRay connections through the active steering (AI) control module?

---

**Note: If the vehicle is not equipped with IAL, there is a terminating resistor installed in the place of the AL control module.**



## Workshop Exercise - F01 Bus Systems and Terminal Resistors

Using an instructor designated vehicle and training aids, locate the terminal resistors for FlexRay. Use ISTA to locate the connections. Complete the exercise by filling in the requested information and answering the pertinent questions:

Using the appropriate test cables, measure the individual resistance values of the individual components and write into the spaces provided:

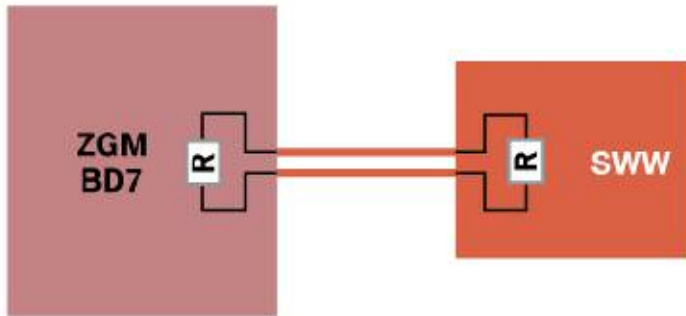

Module	Terminal Resistor Value	Connector #	FlexRay (BP)	FlexRay (BM)
ZGM			pin:	pin:
SWW			pin:	pin:

What should be the result, when checking the total parallel resistance of the FlexRay circuit between ZGM and SWW?

What is your **actual** result when testing the total parallel resistance of the FlexRay circuit between ZGM and SWW?

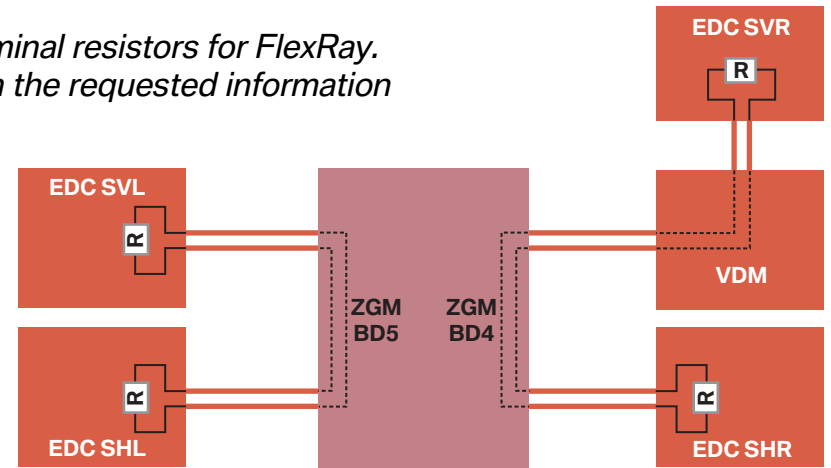

Module	Terminal Resistor Value	Connector #	FlexRay (BP)	FlexRay (BM)
EDC_SVL to ZGM			pin:	pin:
ZGM to EDC_SVL			pin:	pin:
ZGM to EDC_SHL			pin:	pin:
EDC_SHL to ZGM			pin:	pin:
EDC_SHR to ZGM			pin:	pin:
ZGM to EDC_SHR			pin:	pin:
ZGM to VDM			pin:	pin:
VDM to ZGM			pin:	pin:
VDM to EDC_SVR			pin:	pin:
EDC_SVR to VDM			pin:	pin:

What is your **actual** result when testing the total parallel resistance of the Left side and right side (respectively) FlexRay circuit between the EDC satellites?





## Workshop Exercise - F01 Bus Systems and Terminal Resistors (K-CAN 2)

Using an instructor designated vehicle and training aids, locate the terminal resistors for K-CAN 2. Use ISTA to locate the connections. Complete the exercise by filling in the requested information and answering the pertinent questions:

Using the illustration below, circle the control modules which contain the terminal resistors for K-CAN 2:

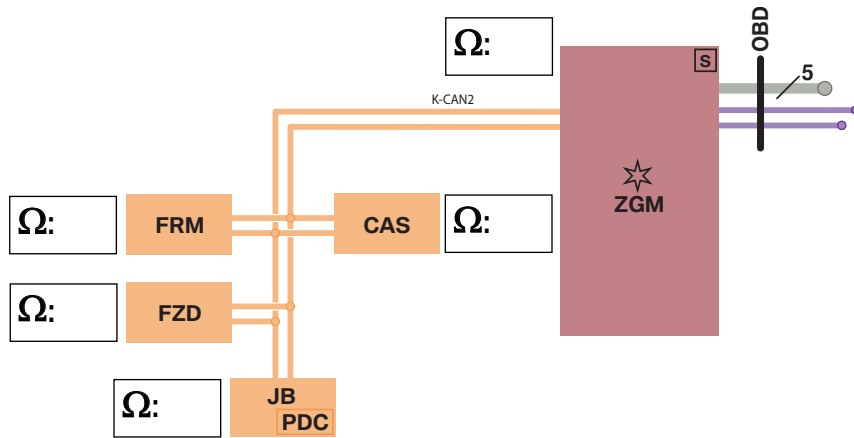

Using the appropriate test cables, measure the individual resistance values of the individual components and write into the spaces provided above:

What should be the result, when checking the total parallel resistance of the K-CAN 2 circuit?

---

---

What is your **actual** result when testing the total parallel resistance of the K-CAN 2 circuit?

---

---

Record the K-CAN 2 connections to the following components for future reference:

Place a "W" next to those modules which are "wake capable":

Module	Wake Capable (KL15 wake-up)	Connector #	K-CAN 2 (high)	K-CAN 2 (low)
ZGM			pin:	pin:
FRM			pin:	pin:
FZD			pin:	pin:
JB			pin:	pin:
CAS 4			pin:	pin:

Which modules on K-CAN 2 are also "wake authorized"?

---

---

---

---

What are the part numbers of the test cable used?

---

---

---



## Workshop Exercise - F01 Bus Systems and Terminal Resistors (D-CAN and Ethernet)

Using an instructor designated vehicle and training aids, locate the terminal resistors for D-CAN. Use ISTA to locate the connections. Complete the exercise by filling in the requested information and answering the pertinent questions:

Using the illustration below, locate the connector and pins for the D-CAN terminal resistor:

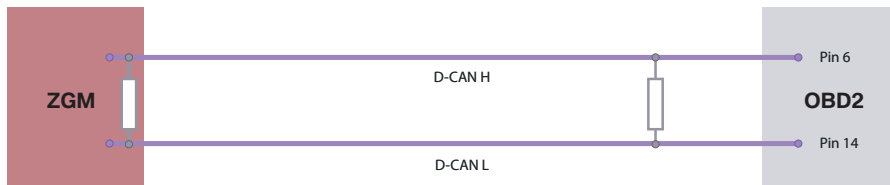

Using the schematics in ISTA, define the pins for the diagnostic connector:

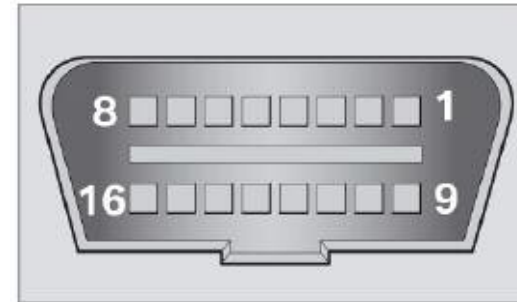

Using the appropriate test cables, measure the individual resistance values of the individual components and write into the spaces provided above:

What should be the result, when checking the total parallel resistance of the D-CAN circuit?

---

What is your **actual** result when testing the total parallel resistance of the D-CAN circuit?

---



---

Where are the terminal resistors located?

---



---



---

Index	Explanation	Index	Explanation
1		9	
2		10	
3		11	
4		12	
5		13	
6		14	
7		15	
8		16	



## Classroom Exercise - Review Questions

- Including PT-CAN, PT-CAN 2 and FlexRay, how many terminal resistors are located inside the ECM (DME)?  
(circle the correct answer)  
**1**                      **2**                      **3**                      **4**                      **5**
- On the F01, the resistance value for the terminal resistors located at each of the EDC satellites is approximately:  
A. 75 ohms              B. 95 ohms              C. 100 ohms  
D. 120 ohms              E. 135 ohms
- On the F01, there are two terminal resistors on PT-CAN 2. When checking the total resistance (in parallel) between the high and low lines, what value should be obtained in a normally functioning (complete) circuit?  
A. 60                      B. 90                      C. 120  
D. 135                      E. 240
- How is diagnostic data transferred to the diagnostic equipment on the F01?  
via D-CAN                      via Ethernet
- When connecting the I-COM A to the F01 using ISTA/P, the programming data is sent to the ZGM via:  
D-CAN                      Ethernet
- On the F01/F02, what is the communication speed on the K-CAN 2?  
A. 100 Kbits/second                      B. 500 Kbits/second  
C. 10 Mbits/second                      D. 22.5 Mbits/second
- The D-CAN circuit on the F01 has two terminal resistors which are located in:  
A. the KOMBI and the ZGM  
B. the KOMBI and OBD2 connector wiring  
C. the ZGM and OBD2 connector wiring  
D. the ZGM and the DME

# Voltage Supply

## Overview of System Components

The voltage supply in the F01/F02 consists of the following components:

- Vehicle battery
- Distribution box on the battery
- Front fuse carrier, behind the glove compartment
- Rear fuse carrier on the right-hand side of the luggage compartment
- Intelligent battery sensor IBS
- SBK safety battery terminal
- Battery cables
- Junction box electronics
- Power distribution box in engine compartment
- Electronics box in engine compartment
- Positive battery terminal
- Alternator.

### Vehicle Battery

The vehicle battery is an 90 Ah AGM type fitted in the center at the rear of the luggage compartment floor. The main advantage of the AGM battery is its higher cycle strength.

### Distribution Box

In the F01/F02, the distribution box is located in the luggage compartment directly on top of the vehicle battery.

The distribution box on the battery is secured on the vehicle battery by means of a metal tab.

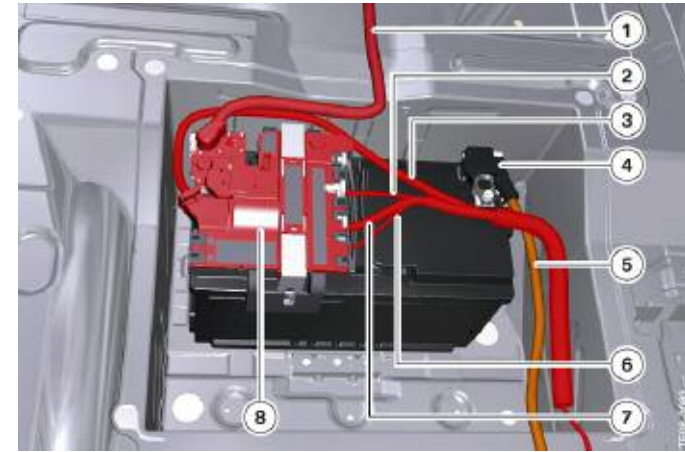

Index	Explanation	Index	Explanation
1	Battery cable, to starter and alternator	5	Negative battery cable
2	Cable to rear fuse carrier	6	Cable to power distribution in engine compartment
3	Cable to front fuse carrier	7	Cable to E-box in engine compartment
4	Intelligent Battery Sensor (IBS)	8	Distribution box on battery

The distribution box on the battery is equipped with fuses for the following electric loads:

- Front fuse carrier (250 A)
- Rear fuse carrier (100 A)
- Engine compartment distribution box (100 A)
  - electric fan
- Electric coolant pump (100 A)
- Intelligent battery sensor IBS.

The distribution box on the battery must always be replaced as a complete unit. The fuses are integrated as a complete unit in the housing of the distribution box on the battery.

The fuses differ in terms of their power rating. The distribution box additionally contains the power supply for the intelligent battery sensor IBS.

The connectors are color-coded and mechanically coded to avoid confusion. These are high power connections, therefore always ensure correct contacting!

**Note: When replacing or working on the distribution box, always make sure the plug connections and, above all, the screw connections are secured properly. Connection between battery terminal and distribution box 15 Nm.**

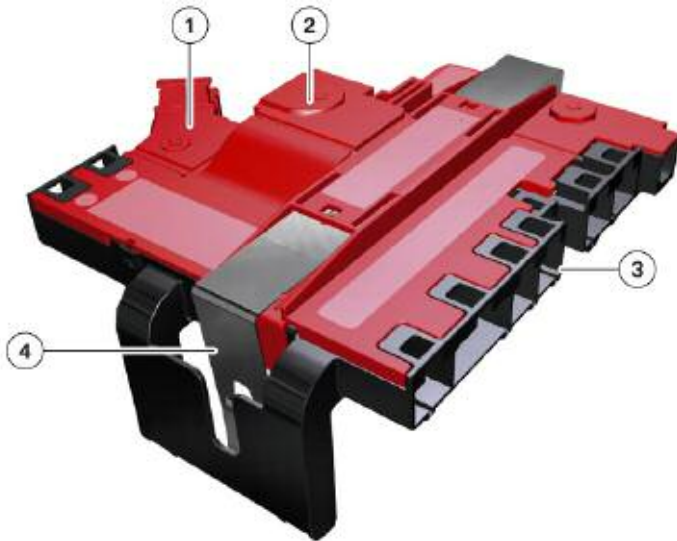

Index	Explanation	Index	Explanation
1	Connection to the battery cable to front fuse carrier	3	High current consumer connections
2	Connection to battery terminal	4	Retaining clip

## Fuse Carriers

Due to the steady increase of electrically operated comfort functions, communication and safety in BMW vehicles, the voltage supply is becoming ever more important.

In the F01/F02, there are two separate fuse carriers. The front fuse carrier is located near to the glove compartment and the rear fuse carrier is located on the right-hand side of the luggage compartment.

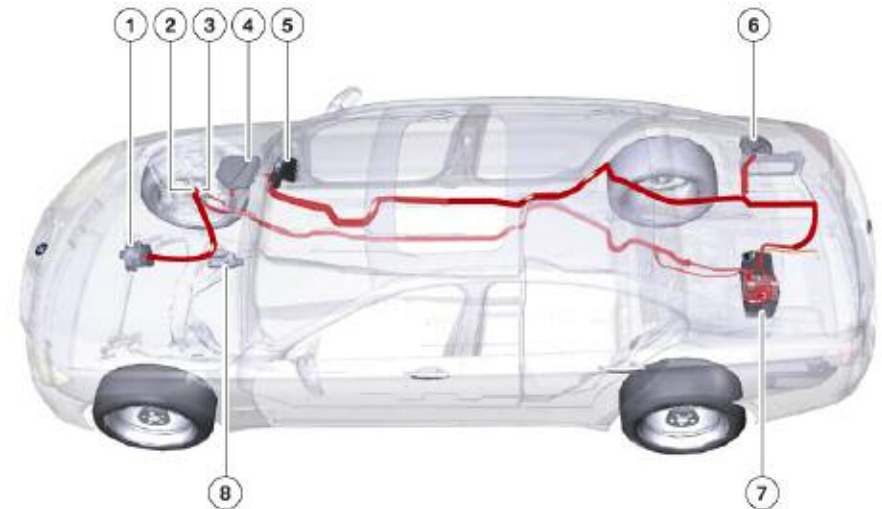

Index	Explanation	Index	Explanation
1	Alternator	5	Front fuse carrier (behind glove compartment)
2	Positive battery terminal (B+ Junction)	6	Rear fuse carrier, luggage compartment, right side
3	Power distribution box, engine compartment	7	Battery
4	Electronics box, engine compartment	8	Starter

## Front Fuse Carrier

This section describes the front fuse carrier. The junction box electronics are described in a later section. In the right-hand part of the front fuse carrier, there is an opening through which the junction box electronics are connected to the front fuse carrier.

### ■ Installation Location

The installation location of the front fuse carrier is underneath the dashboard on the right-hand side. In order for a fuse to be replaced, the glove compartment must be opened.

## Front Fuse Carrier and Junction Box Electronics

The connection between the front fuse carrier and the junction box electronics is established through the opening in the right-hand area of the fuse carrier. An internal plug connection provides the electrical connection between the two components.

When assembled, the two components form a single unit (junction box) consisting of the junction box electronics and the front fuse carrier.



## Relays in the Front Fuse Carrier

There are a few relays in the front fuse carrier. One of these is plugged in, the others are soldered to the circuit board.

### ■ Connected relay



Index	Explanation
1	Relay, KL30 B



## ■ Soldered Relay

Various relays are soldered to the circuit board in the front fuse carrier. In the event of a fault, the fuse carrier must be replaced as a complete unit.

### Internal view of front fuse carrier, F01/F02

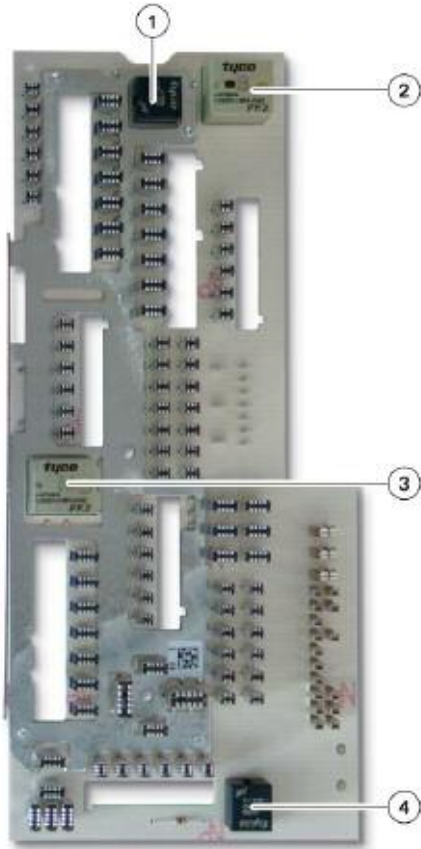

Index	Explanation
1	Relay, KL30 F (bistable) (soldered)
2	Relay for headlight cleaning system (soldered)
3	Relay, terminal 15N (soldered)
4	Horn relay (soldered)

## Rear Fuse Carrier in the Luggage Compartment

Due to the large number of consumers and control units in the F01/F02, an additional fuse carrier has been fitted in the luggage compartment.

As well as the fuses, a few relays are plugged in here or soldered to the circuit board.

If one of the soldered relays is faulty, the rear distribution box must be replaced as a whole unit. The connection port of the battery cable is located on the rear of the fuse carrier.

### Rear fuse carrier, F01/F02

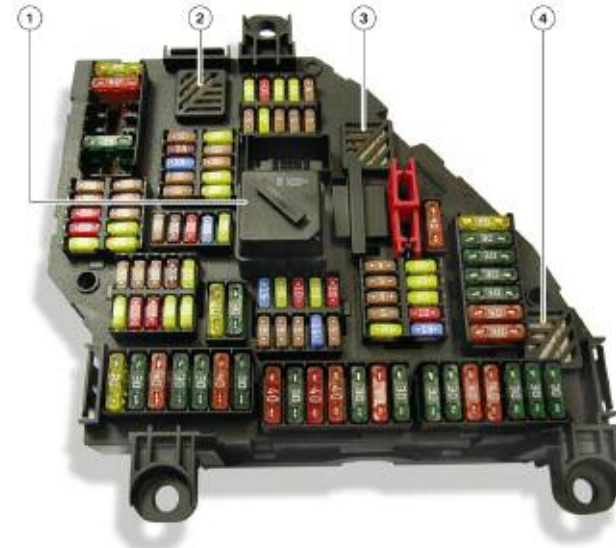

Index	Explanation	Index	Explanation
1	Relay, KL30B, plugged in	3	Relay, KL15N (soldered)
2	Relay, KL30F (soldered)	4	Relay for rear defogger heating element (soldered)

## Power Distribution Box in Engine Compartment

There are no fuses in the engine compartment distribution box.

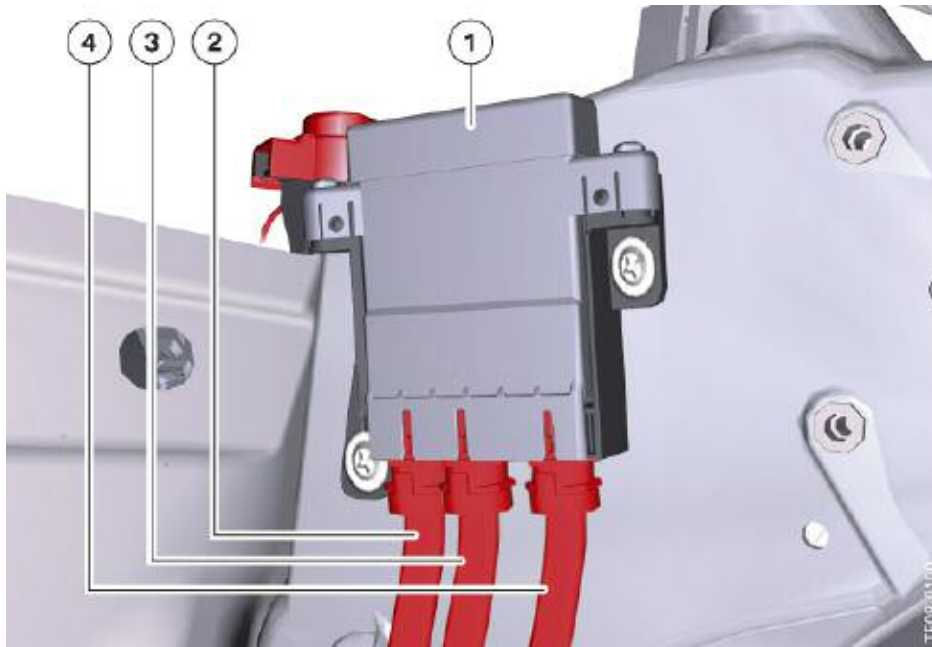

Index	Explanation	Index	Explanation
1	Power distribution box	3	Cable to electric fan
2	Cable from distribution box to battery	4	(Not for US)

## Battery Cables

In the F01/F02, three main power lines on the underbody run from the distribution box at the battery to the engine compartment. One of the main power lines runs via the positive battery terminal to the starter motor and to the alternator.

The second line powers the engine electronics (Electric coolant pump etc). The third line runs to the distribution box in the engine compartment. This distribution box supplies the electric fan with power.

This line is safeguarded by the high-current fuse (100 A) in the distribution box at the battery. Depending on the model of vehicle, different line cross sections are used.

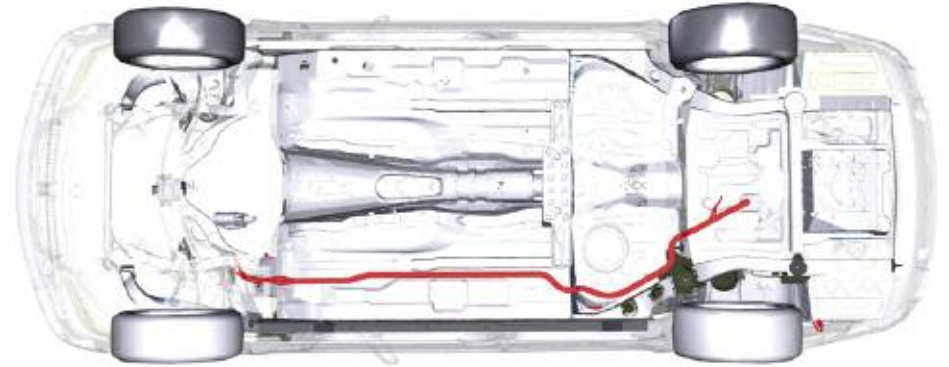

In addition, a battery cable is routed to the front fuse carrier through the vehicle interior. The transfer points for the main power cables are located in the luggage compartment. The main power lines on the underbody are laid in a protected area to prevent damage.

## Intelligent Battery Sensor (IBS)

The intelligent battery sensor (IBS) is a mechatronic component for monitoring the battery status. The following physical measurements are recorded for the battery:

- Current
- Voltage
- Terminal temperature

The term "intelligent" means that there is a microprocessor integrated in the IBS. This microprocessor calculates and analyzes time critical measured variables. The results are then forwarded to the higher-level control units (i.e. DME) via the LIN bus.



# Voltage Supply Circuit Diagram

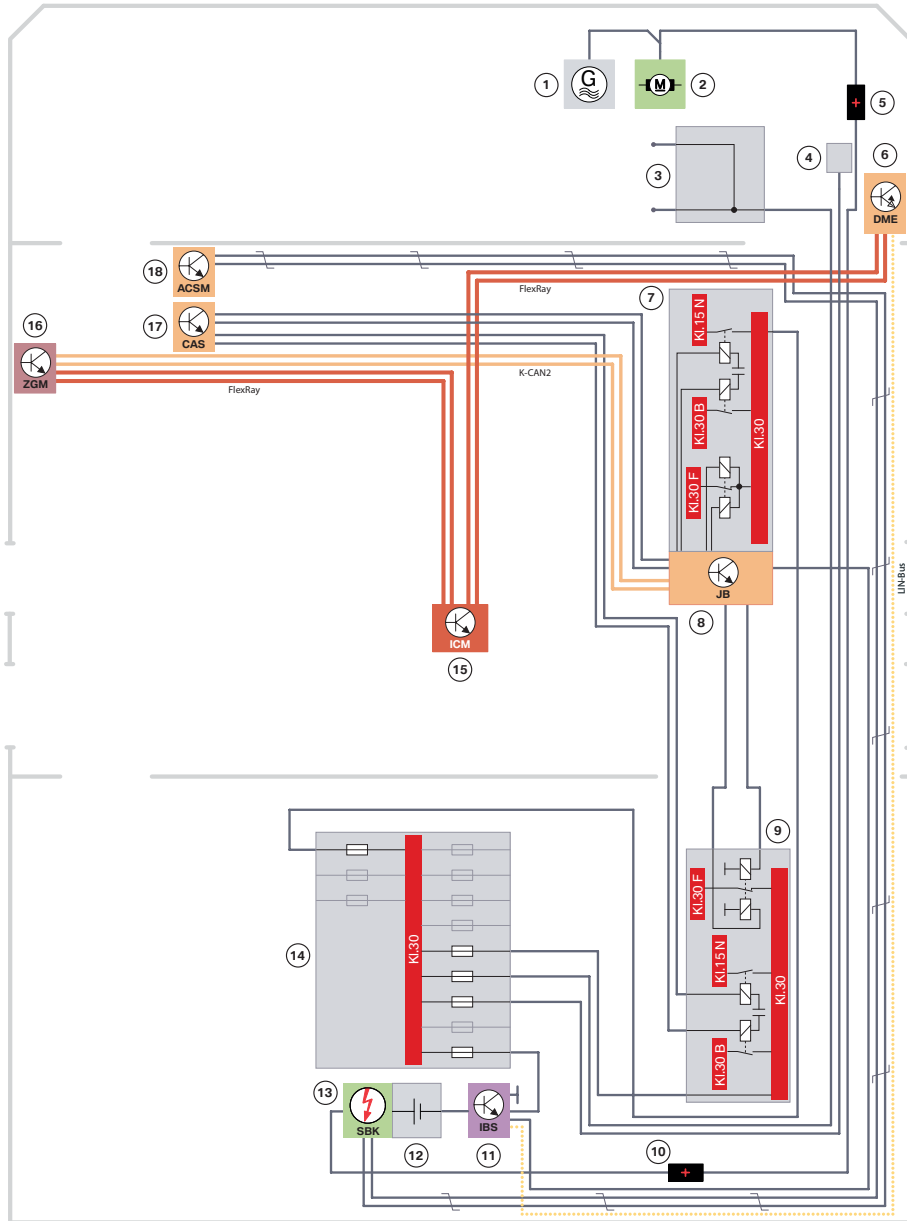

Index	Explanation
1	Alternator
2	Starter
3	Power distribution box, engine compartment
4	Electronics box, engine compartment
5	Positive battery terminal (B+ junction)
6	Digital Motor Electronics (DME)
7	Front fuse carrier (behind glove compartment)
8	Junction box electronics
9	Rear fuse carrier, luggage compartment, right side
10	Transfer point on luggage compartment floor
11	Intelligent Battery Sensor (IBS)
12	Battery
13	SBK Safety Battery Terminal (SBT)
14	Distribution box, on battery
15	Integrated Chassis Management (ICM)
16	Central Gateway Module (ZGM)
17	Car Access System (CAS)
18	Advanced Crash Safety Module 3 (ACSM 3)
KL30	Terminal 30 (Continuous Positive)
KL30B	Terminal 30B (basic operation)
KL30F	Terminal 30F (fault switched)
KL15N	Terminal 15N (Overrun)

# Energy Management

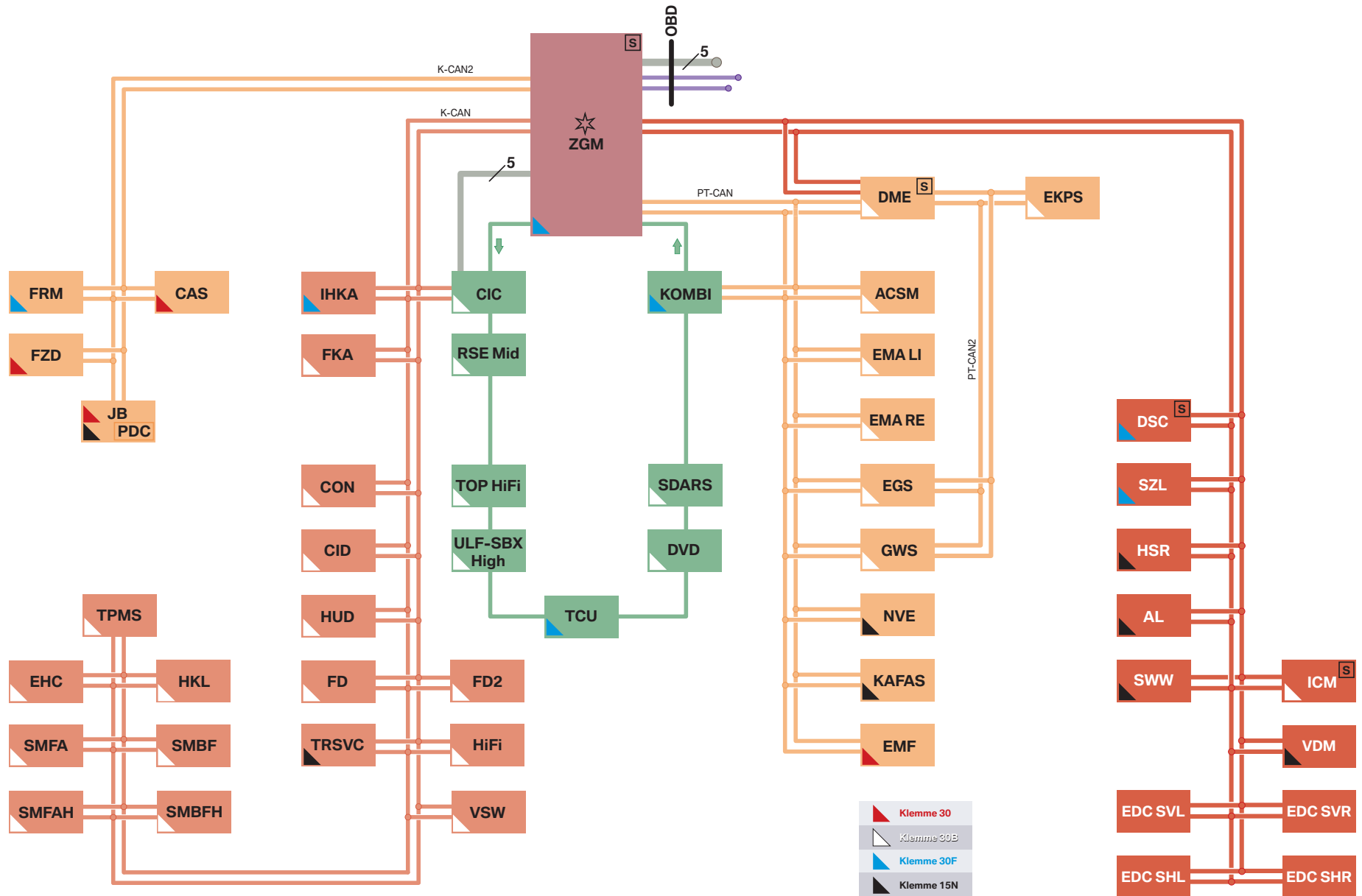

## Bus Overview and Terminal Status

The F01/F02 introduces new designations for some of the terminals. A distinction is also made between logical terminals and power supply terminals.

The logical terminals do not serve as power supply terminals; instead, they represent a status. They are activated/deactivated by pressing the START-STOP button.

The logical terminals are:

- Terminal R
- Terminal 15
- Terminal 50.

The power supply terminals on the F01 has been changed, the following table reflects the changes:

Previous terminal designations	New terminal designations
KL15	KL 15N
KL30g	KL 30B
KL30g_f	KL 30F
KL30	KL30

For clearer illustration of terminal shut-down, the control units are identified by a colored triangle. Identification and allocation to the individual terminals are shown in the diagram below.



### Terminal 15N

Terminal 15N is used to supply power to control units and components that are only intended to be active when the vehicle is being driven, e.g. PDC.

The letter N stands for "Nachlauf", meaning "overrun". The power supply Terminal 15N is switched on and off by means of the logical Terminal 15. The overrun time after Terminal 15N is switched off is 5 seconds. That time is required so that the control units have enough time to save their data. While Terminal 15N is active, Terminal 30B and Terminal 30F are also active.

### Terminal 30B

Terminal 30B supplies power to control units and electrical components that are required when the driver is present.

The letter B stands for "Basic mode".

Terminal 30B is activated by:

- Pressing the buttons on the radio remote control
- Unlocking/locking/double-locking the vehicle
- Pressing the START-STOP button
- Change of door switch status, change of trunk switch status, change of side window position
- Bus message.

Regular deactivation by:

- Vehicle double-locked and trunk closed (one minute overrun)
- Vehicle not double-locked or trunk open (30 minutes overrun).

Other possible deactivation triggers:

- Upper starting capacity limit reached (one minute overrun)
- "Powerdown": diagnosis command for purposes of measuring closed-circuit (10 seconds overrun)
- Transport mode (one minute overrun).

While Terminal 30B is active, Terminal 30F is also active.

### Terminal 30F

Terminal 30F supplies power to control units and electrical devices that are also required when the driver is not present but which can be switched off in the event of a fault.

All control units that are not supplied by Terminal 15N or Terminal 30B, are not responsible for vehicle access and do not have to meet a legal requirement for permanent operation.

The letter F stands for "Fault".

Terminal 30F is activated by:

- Pressing the buttons on the radio remote control
- Unlocking/locking/double-locking the vehicle
- Pressing the START-STOP button
- Change of door switch status, change of trunk switch status, change of side window position
- Bus message.

In the event of a fault (closed-circuit current too high, bus wake-up, sleep-mode inhibitor, start capacity limit reached) Terminal 30F is reset for 10 seconds.

Terminal 30F is not reset or switched off if at least one of the following conditions is met:

- Terminal 30B active
- Parking lights switched on
- Side lights switched on
- Hazard warning lights switched on
- If an extended overrun time for Terminals 30B and 30F is demanded by a service message from any of a number of control units.

**Example:** when the engine is warm, it can be necessary for the electric fan to run on for up to 11 minutes after the vehicle is parked and locked. In order for the electric fan to be operated, the engine management module must be supplied with power. Since the overrun time in that case is only three minutes (that is currently the short overrun time for Terminal 30B, not one minute), the DME requests the appropriate extension by way of a bus message when the engine is switched off.

- "Sticking relay" detected.

Terminal 30F is switched off if Terminal 30B is off and at least one of the following conditions is met:

- Starting capacity limit reached
- Another 10 bus wake-ups have occurred after Terminal 30F reset
- Unexplained bus activity after Terminal 30F reset
- Violation of closed-circuit current limit detected after Terminal 30F reset.



## Workshop Exercise - Logical Terminal Control

*Using the supplied poster and the instructor designated vehicle, solve the exercise as outlined by your instructor. Complete by answering the following questions.*

When pressing the START/STOP button once (engine off), without depressing the brake, what terminals can be switched on and off?

---

---

How is Terminal R achieved?

---

---

When in Terminal R, what happens when the START/STOP button is pressed?

without depressing the brake

---

---

when depressing the brake

---

---

How long will the vehicle stay in KLR? (without changing any status i.e. doors or remote control operation)

---

---

---

---

When the engine is running, what happens when the START/STOP button is pressed while the transmission is in Neutral?

---

---

How long will the vehicle stay in KL15 after shutting the engine off (in Neutral)?

---

---

What, if anything, will extend the time in KL15 in the above situation?

---

---

What happens if there is an attempt to lock the vehicle with the remote while the vehicle is in neutral (in KL15).

---

---

Why would it be necessary to shut off the engine with the transmission in Neutral?

---

---

---

---

## Terminal Relays

The F01/F02 has various relays for switching off the power supply to most control units. The Junction box module controls the bistable relays for Terminal 30F but receives the request from the central gateway module (ZGM) or IBS.

- ZGM:

If sleep mode inhibited or on occurrence of unauthorized wake-up. ZGM monitors the vehicle status and registers inhibited sleep mode or unauthorized wake-up after Terminal 30B is switched off.

- IBS:

If closed-circuit current limit violated or starting capacity limit reached.

The computation for activating the Terminal 30F relay takes place on two control units. The ZGM monitors the following activities:

- Invalid wake-up procedures within the bus systems
- Sleep blockers (control units that constantly keep the bus systems active).

Location	Relay	Connection	Controlled by
Front fuse box	KL 15N	Soldered	CAS
Front fuse box	KL 30B	Plugged in	CAS
Front fuse box	KL 30F (bistable)	Soldered	ZGM/DME
Rear fuse box	KL 15N	Soldered	CAS
Rear fuse box	KL 30B (bistable)	Plugged in	CAS
Rear fuse box	KL 30F	Soldered	ZGM/DME

The ECM (DME) continuously reads and assesses the battery data. The relay is also switched off when the starting capability limit of the vehicle battery is reached.

The Terminal 30F relay is a bistable relay and is always in the ON state under normal conditions. It switches off the connected electric loads only in the case of fault. Once the Terminal 30F relay has been switched off, one of the switch-on conditions must be met before it can be switched on again.

### ■ General Measures

The terminals "load shut-down" and the terminal "interior lighting" are switched off as a general measure when the vehicle is in stationary mode. This occurs only when the vehicle is not locked and secured. These loads are shut down immediately when the vehicle is locked and secured. This measure affects the following electric loads:

Electrical loads	Terminal
Interior lighting (front and rear)	Load shut-down after 8 minutes (immediately if doublelocked)
Footwell lighting (front and rear)	Load shut-down after 8 minutes (immediately if doublelocked)
Reading light (front and rear)	Load shut-down after 8 minutes (immediately if doublelocked)
Vanity mirror light	Load shut-down after 8 minutes (immediately if doublelocked)

## Intelligent Battery Sensor (IBS)

The intelligent battery sensor has a similar range of functions to the intelligent battery sensor on previous models. A new feature is data transmission between the IBS and the ECM (DME) via LIN bus and the wake-up function of the IBS.

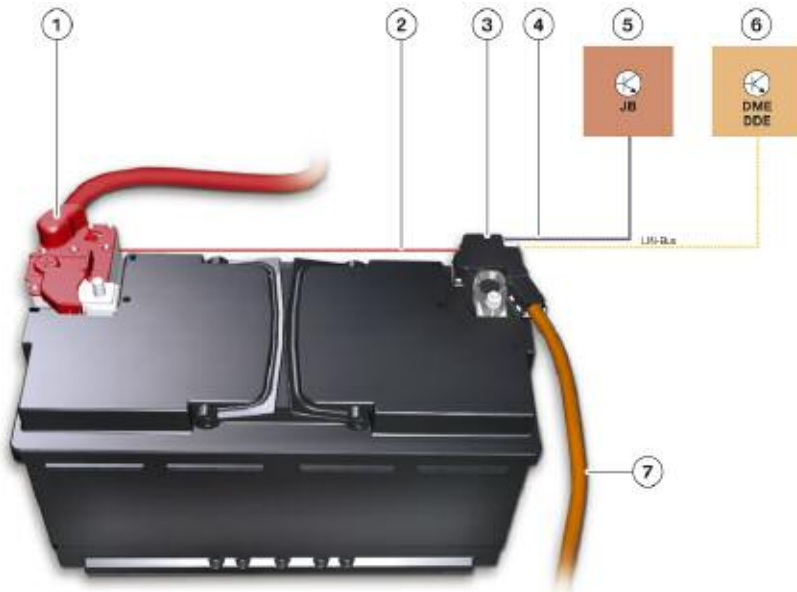

Index	Explanation	Index	Explanation
1	Battery positive lead	5	Junction box module
2	Power supply for IBS	6	ECM (DME)
3	IBS	7	Battery negative lead
4	Wake-up line		

### Wake-up Function

When the vehicle is in idle mode, the IBS continuously records the data relevant to the battery indicators. The IBS is programmed to wake up every 14 seconds in order to update the measured data by taking new readings.

The time required to take the readings is approximately 50 milliseconds. The measured data is stored on the IBS in the memory for recording the closed-circuit current.

The wake-up function applies only when the vehicle is in idle mode. If the IBS detects a wake-up trigger, the Junction box module is woken up by a PWM signal. The IBS is directly connected to the Junction box module via a separate lead.

The pulse duty factor indicates the reason for the wake-up:

Duty factor	Reason for wake-up
20%	Starting capacity limit 1
40%	Starting capacity limit 2
60%	Raised closed-circuit current

A wake-up due to raised closed-circuit current can take place up to three times. Depending on the vehicle status and reason for the wake-up, the Junction box module performs one of the following actions:

- Wakes up the vehicle so that the DME can send shut-down commands to electrical devices that are operating while the vehicle is in parked mode
- Resets Terminal 30F (without waking up the vehicle)
- Switches off Terminal 30F (without waking up the vehicle).

A fault memory entry is registered in each case.

## Commissioning

The IBS is fully functional as soon as it is completely connected, i.e. it can immediately detect the basic variables, current, voltage and temperature.

However, the variables derived from those readings for the purposes of power management, i.e. battery condition, starting capacity, etc., must first be recalculated and, therefore, there is a time lag before they are available.

When the engine is restarted, the DME reads off the closed-circuit current progression. If it diverges from the defined closed-circuit current progression, a fault is registered in the DME fault memory.

In the period between "Engine OFF" and when the DME main relay is switched off, the IBS is informed by the DME as to the maximum charge that can be drawn from the battery on the basis of ensuring that the engine can be reliably restarted.

After the DME main relay is switched off, the IBS continually checks the battery charge level (SOC) and the closed-circuit current.

## ■ Junction Box Module

The Junction box module is responsible for switching the Terminal 30F relay and for storing information (history data and fault memory entries) related to energy management.

As part of vehicle diagnostics, these data can be used to evaluate faults and to analyze the vehicle battery.



## ■ Engine Management (power management)

The (power management) software for controlling the energy balance is located in the engine management (DME). On the basis of that control algorithm, various electrical devices in the vehicle's electrical system are switched off by the CAS control unit via the Terminal 30B relay or by the Central Gateway Module and engine management module via the Terminal 30F relay. The power management is additionally responsible for evaluating and storing the IBS data.







## Transport Mode

The batteries in vehicles coming off the production line are adequately charged so that SOC > 80 % (SOC = "State of charge").

However, since several days or weeks can pass between the time the vehicle comes off the production line and when it is delivered to the customer, the battery will have discharged to a greater or lesser degree. Therefore, every battery must be charged according to the recharging calendar.

The F01/F02 is the first model on which it is possible to display the charge level of the battery when the new car is being transported.

Battery condition	Display (Cluster)	Audible signal	Action
Battery condition OK (SOC 60% to 100%)		No sound	No action necessary
Battery is discharged (SOC 35% to 60%)		No sound	Charge battery
Battery charge level is very low (SOC less than 35%)		Double gong	Replace battery

When production or transport mode is activated, a Check Control message is generated that provides a quick indication of the battery condition.

**Note: If the SOC has dropped to less than 35 %, the indication continues to be displayed on the instrument cluster until the battery is replaced and a change of battery is registered.**

**Note: When transport mode is reset, there is no indication on the instrument cluster of the battery charge level.**

**Note: If the vehicle is delivered with the red Check Control message "Battery charge level very low" active, it is essential that the low battery charge is recorded as "transport damage" on the delivery note.**

In such cases, the test module "Energy diagnosis" must be carried out to establish the cause.

**Replace the battery before handing over the vehicle to the customer and register the change of battery using the service function.**

**Note: If a vehicle is delivered with the yellow Check Control message "Charge battery", this should also be recorded on the delivery note. The battery must then be charged once and an energy diagnosis carried out.**

## Closed-circuit Current

Upwards of a closed-circuit current level of 80 mA, a Check Control message is generated (raised battery discharge rate when parked).

The graphs below shows the typical closed-circuit current progression on the F01/F02 associated with the various electrical system statuses. The actual current values change depending on the vehicle equipment configuration.

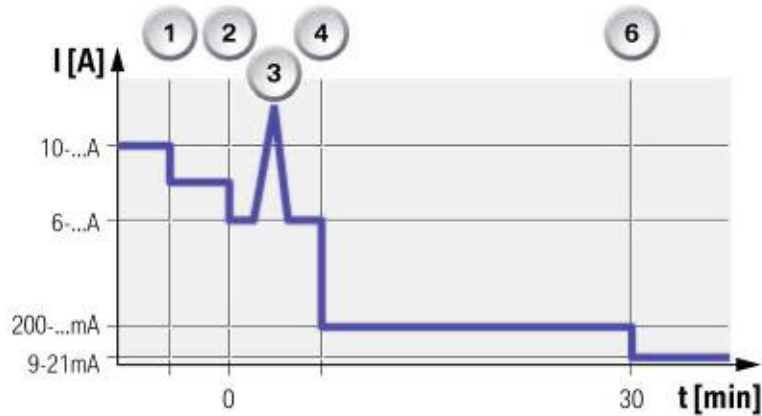

### Typical closed-circuit current progression for double-locked vehicle on F01/F02

The terminal "load shut-down" (e.g. reading light and vanity mirror light) is switched off corresponding to the terminal status.

Load shut-down switches off immediately when the vehicle is secured. In all other terminal statuses, the load shut-down terminal is switched off after an overrun period of 8 minutes. It is activated by the footwell module.

Typical closed circuit current on the F01/F02 is between 9 and 21 mA.

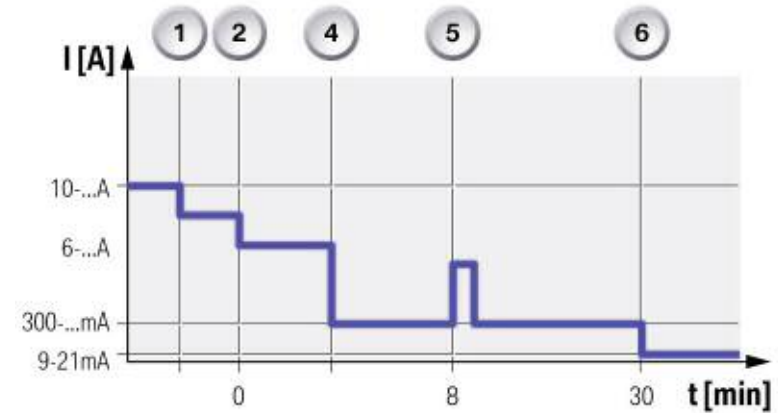

### Typical closed-circuit current progression for unlocked vehicle on F01/F02

Index	Explanation
1	KL15N Off
2	KL R Off
3	Vehicle is secured
4	Start of bus rest phase
5	Electrical load shutdown after 8 minutes
6	Terminal 30B Off (30 minutes without phone or 60 minutes with)

## Electrical System and Battery Diagnosis

Over the past few years, the energy management of all BMW models has been continuously improved and standardized across the various model series. In terms of energy diagnosis, this also means standardization of testing schedules and displays in the BMW diagnostic system.

The aim of the diagnostic procedures is to show the causes of a discharged battery as unambiguously as possible. In view of the complexity, especially in the area of energy management, the specific cause of a fault can be shown only partially depending on its nature.



The acquired energy diagnosis data are shown if the fault cannot be clearly assigned based on the acquired data. Power management is retained in full while the expanded diagnostic options are now resident in the history memory.

ZGM monitors the vehicle status, registers inhibited sleep mode or unauthorized wakeup after Terminal 30B is switched off and requests a reset or shut-down of Terminal 30F by a bus message to the JBE.

The originator and reason for wake-up (unauthorized wake-up) are stored as additional information in the ZGM fault memory. The driving profile for the last 5 weeks is stored in the JBE energy history memory. The energy history memory is referred to for energy diagnosis purposes.

More information on the subject of energy management on the F01/F02 can be found in the BMW Diagnosis System.

NOTES

PAGE

---

NOTES

PAGE

NOTES

PAGE

---

NOTES

PAGE

# Car Access System

## CAS 4

The Car Access System introduced on the F01 is now the 4th generation. There are several changes as compared to past vehicles which include:

- Integration of the Comfort Access functions into CAS 4
- Passive Go is now standard equipment (1st time for BMW)
- Elimination of slot for ID transmitter (key)

Comfort Access remains an option, but Passive go is standard. Therefore, the ID transmitter only needs to be somewhere inside the passenger compartment for the engine to be started.

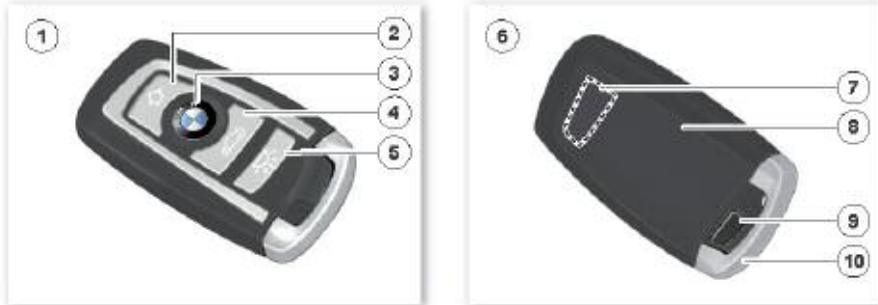

Index	Explanation	Index	Explanation
1	ID transmitter, top view	6	ID transmitter, rear view
2	Unlock vehicle button	7	Location of emergency start coil
3	Lock vehicle button	8	Battery compartment
4	Unlock trunk button	9	Release button for mechanical key
5	Panic mode (US)	10	Mechanical key

The ID transmitter is fitted with a battery which has a life of approximately four years. Up to eight ID transmitters can be used for a particular vehicle. Four of the eight ID transmitters can be used for personal profiles.

### Functional Overview

The Car Access System 4 provides, among other things, the central control unit for vehicle access and vehicle locking. Consequently, the CAS 4 has complete control over central locking.

The CAS 4 has sole knowledge of the system and decides whether, for instance, to allow access to the vehicle or not. In other words, whether to unlock the vehicle or not. That function is referred to as a master function.

The Car Access System 4 incorporates the following master functions on the F01/F02:

- Comfort Access
- Central locking
- Power windows
- Sliding/tilting sunroof
- Terminal control
- Electronic immobilizer 4

Other functions of the CAS 4 include:

- Vehicle data storage
- Data transmission for Condition Based Service (CBS).
- Checking plausibility of remote control signals.



The Car Access System 4 enables or disables the execution of a number of functions. However, other control units may be involved in the execution of the function. A selection of them is listed in the table below.

Selection of function-executing control modules	
JBE	Central locking
FRM	Power windows
FZD	Sliding/tilting sunroof

For the purposes of communication with other electrical-system devices, the CAS 4 is connected to the K-CAN2, CAS bus and LIN bus.

The Car Access System 4 analyzes the status of the hood switch and broadcasts this information for use by the alarm system.

The Car Access System 4 also analyzes the status of the following buttons and initiates the central locking function:

- Center Lock button, locking/unlocking central locking
- Interior trunk release button on A-pillar, unlocking trunk
- Central double-locking button, locking and double-locking vehicle doors using button on underside of open trunk
- Hotel setting switch, preventing trunk unlocking function.

The Car Access System 4 provides the power supply for the brake light switch and also analyzes its status.

The sections that follow describe some of the functions of the Car Access System. Those functions are:

- Terminal control
- Electronic immobilizer
- Gearbox enable
- Vehicle data storage.

## ID transmitter search in passenger compartment

When the START-STOP button is pressed, it triggers the search for an ID transmitter in the passenger compartment. The passenger compartment search is required for the Passive Go function in order that starting can be enabled.

When performing the passenger compartment search, the CAS 4 issues a request for an ID transmitter to register with the vehicle.

There are two antennas provided for the passenger compartment search. One antenna covers the front of the passenger compartment and the other the rear. The antennas are connected to the CAS 4.

The CAS 4 sends out a signal with a frequency of 125 KHz through the antennas. That signal triggers the ID transmitter to register with the vehicle.

The ID transmitter responds with an encrypted radio signal. The remote control receiver in the diversity module passes the radio signal information to the CAS 4 via the LIN bus.

The CAS checks whether the ID transmitter belongs to the vehicle. Subsequent communication takes place on the ID transmitter's transmission frequency, e.g. 315 MHz

The CAS 4 checks whether the ID transmitter matches the vehicle. If the check is positive, the CAS 4 enables terminal control. The individual terminals can then be selected.

**Note: If communication with the ID transmitter can not be established, a Check Control message is displayed on the instrument cluster. The driver is notified that no ID transmitter could be located inside the passenger compartment.**

The ID transmitter can be held in the position marked on the steering column. There is an emergency start coil under the steering column trim. Communication between the CAS 4 and the ID transmitter can be established via the emergency start coil.

### ■ Input/Output CAS 4

The Car Access System 4 (2) is responsible for terminal control. For instance "Terminal 15 ON" is made available to the intelligent battery sensor (4). The terminal statuses, e.g. "Terminal 15 ON/Terminal 0", can be selected by means of the START-STOP button (11). In conjunction with the digital motor electronics (3), the Car Access System 4 issues the start enabling signal for the starter motor (5).

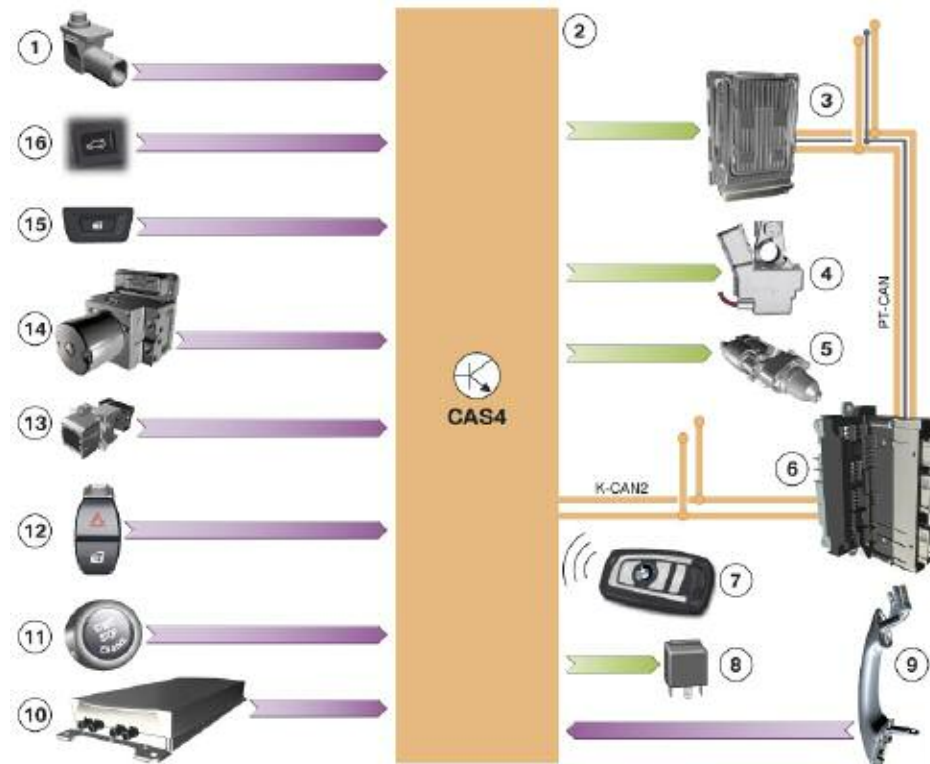

Index	Explanation	Index	Explanation
1	Hood switch	9	Door handle module (TAGE)
2	CAS 4	10	TCU
3	DME	11	START-STOP button
4	IBS	12	Central-lock button
5	Starter	13	Brake light switch (BLS)
6	JBE	14	DSC
7	Identification transmitter (key)	15	Central, double lock button
8	KL 15	16	Interior trunk release button

## Electronic Immobilizer 4

The EWS 4 was first introduced with the Car Access System 3 on the E92 and the latest version is a derivation of that design.

### Design of the EWS 4 System

The vehicle immobilizer consists of the identification transmitter which identifies itself to the vehicle and therefore to the CAS 4. The CAS 4 system exchanges data via the CAS bus with the digital motor electronics in order to cancel the immobilizer function.

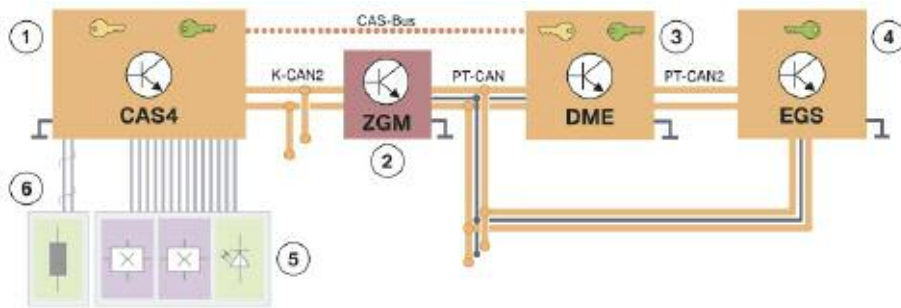

Index	Explanation	Index	Explanation
1	CAS 4	4	Electronic Transmission Control
2	Central Gateway Module	5	START-STOP button
3	Digital Motor Electronics	6	Transponder coil

The software for the electronic immobilizer and for enabling engine starting is incorporated in the Car Access System 4.

Enabling of ignition and fuel injection is the responsibility of the digital motor electronics. Before the electronic immobilizer issues the enabling signal for starting, the ID transmitter must be identified as matching the vehicle.

As soon as an attempt is made to start the engine, a check (authentication) has to be carried out. That check establishes whether a matching ID transmitter is located in the passenger compartment. The vehicle can be started if the check is successful. Authentication starts with the status "Terminal 15 ON".

**Note: The ID transmitter also has to identify itself to the vehicle and, therefore, to the Car Access System 4.**

**Note: The time taken to search for an ID transmitter in the passenger compartment may result in a delay before engine starting is enabled. That delay may occur in a time span of up to half a second.**

### Start enable through the electronic vehicle immobilizer

The start procedure is enabled by means of a special request and response procedure known as challenge-response.

As of "Terminal 15 ON", the digital motor electronics sends an encrypted random number to the CAS 4. The digital motor electronics uses a random number generator to generate the random number.

On the basis of that random number and its secret key, the CAS 4 calculates a response and sends it to the digital motor electronics. In the meantime, the digital motor electronics calculates the expected response from the random number and its secret key.

The CAS 4 and the digital motor electronics use the same secret key and algorithm for the calculations. If the figure that the CAS 4 sends to the digital motor electronics matches the figure calculated by the motor electronics, the electronic immobilizer is deactivated. The engine can now be started.

**Note: As from "Terminal 15 ON", a cyclic query (challenge-response) is performed as long as the engine is not yet running.**

### Data Transmission

Data transmission is redundant via the bus systems.

The signal from the digital motor electronics, for instance, reaches the CAS via both the K-CAN2 and the CAS bus. The digital motor electronics, however, is connected to the PT-CAN.

For that reason, the signal is transferred from PT-CAN to the K-CAN 2 by the central gateway module. The time taken by the signals via the different bus systems is of no consequence as the signal that reaches the digital motor electronics first used for the electronic immobilizer.

The authentication is repeated in response to following events:

- Transmission and response time exceeded
- Transmission problems
- Response with the secret security code incorrect (e.g. incorrect secret key due to control unit from another vehicle).

### Secret Key

The control units are assigned a secret key on the assembly line. This secret key is generated from a random number. The secret key is valid for a pair of control units and linked to the specific vehicle. This means that one pair of control units receives the same secret key.

Once the secret key has been entered, the control unit is locked. From this point on, the control unit is permanently tied to this secret key and the vehicle.

The CAS 4 and the digital motor electronics form a control unit pairing.

**Note: Since the control units are assigned to the specific vehicle, replacement with a unit from another vehicle is not possible.**

**When replacing a control unit, the new control unit must be ordered from BMW. Matching of the control units to each other is no longer necessary.**

### ■ Gearbox Enable

The enable is based on a procedure similar to that used for the electronic vehicle immobilizer 3.

As of "Terminal 15 ON", the CAS 4 sends encrypted individual codes to the transmission control unit. The signal is applied to the PT-CAN 2 by the digital motor electronics.

The electronic transmission control deciphers and checks these individual codes. If the check is successful, the gearbox control unit will enable the gearbox functions.

The electronic gearbox control unit forms a pair of control units together with the CAS 4.

### ■ Start Value Matching

A start value matching procedure between the CAS 4 and the electronic transmission control is performed on the assembly line. That involves the CAS 4 transferring an encrypted individual code to the transmission control unit.

Consequently, the electronic transmission control knows the individual code and can check whether the gearbox functions can be enabled.

## Components of the Car Access System

### CAS 4

Due to the integration of the Passive Go function, the START-STOP button is now connected to the Car Access System 4 via the instrument panel wiring harness.

The CAS has a separate connector socket for the Comfort Access system. The CAS 4 has three connector sockets in all.



Index	Explanation
1	Cockpit connector, 26-pin
2	Comfort access connector 26-pin
3	Vehicle wiring harness connector 41-pin

**Note: The instrument panel is pre-assembled so that it is fitted in the car as a complete unit on the assembly line. For that reason, the Car Access System 4 has only one connector for the main wiring harness.**

**All other connectors are connected up during pre-assembly of the instrument panel.**

On vehicles without Comfort Access, the Car Access System does not have the Comfort Access connector socket (2).

### START-STOP Button

The START-STOP button is integrated in the instrument panel. In contrast with the previous connection, the ribbon cable has been eliminated.

### Emergency Start Coil

In unfavorable situations, the system may not be able to find the ID transmitter in the passenger compartment. For that reason, the Car Access System initiates display of a message on the instrument cluster.

The message notifies the driver that no ID transmitter could be located inside the passenger compartment.

Since the F01/F02 does not have a slot for the ID transmitter, there is an emergency start coil (1) on the steering column.



The emergency start coil can be used to communicate with the ID transmitter so that the engine can still be started and the vehicle driven.

The emergency start coil is equivalent to the function of the transponder coil. By communicating via the transponder coil, the Car Access System 4 is able to identify a valid ID transmitter.

Thus the Car Access System 4 is able to issue the start enabling signal following successful identification.

In the following situations, for example, the system may not be able to find the ID transmitter:

- ID transmitter defective
- Interference with radio transmission to ID transmitter
- Discharged battery in ID transmitter.

## Remote Control Receiver

The remote control receiver now has a transmitter and receiver unit and is integrated in the diversity module. As a result, bi-directional communication can be established between the ID transmitter and the remote-control receiver.

The remote control receiver now also has a LIN bus connection. The remote control receiver uses that LIN bus connection to wake up the Car Access System 4.

In that case, the Car Access System 4 asks the remote control receiver if there is a message waiting. That message may contain a request to unlock the vehicle. The Car Access System checks, for instance, whether the ID transmitter belongs to the vehicle.

If the check is positive, the Car Access System 4 initiates unlocking of the vehicle.

**Note: As a LIN-bus device, the remote control receiver is an input capable of waking up the Car Access System.**

## Input Components

The Car Access System 4 analyzes buttons for the central locking functions. All buttons connect to ground. That means that the Car Access System 4 receives a low signal when the button is pressed.

The buttons concerned are:

- Center-lock button
- Interior trunk release button on A- pillar
- Central double-locking button on underside of trunk
- Hotel setting switch
- Hood switch (alarm system).

## Vehicle Data Storage

The Car Access System 4 stores the following vehicle data:

- Personal Profile, the Car Access System 4 stores data for the Personal Profile
- Vehicle order, the vehicle order is stored in the footwell module
- Redundant data storage for instrument cluster
- Data for condition-based service CBS
- Service key data (e.g. data for Condition Based Service, fault memory entries, Check Control messages, etc.)
- Authentication for diagnostic access to the CAS 4

The Car Access System's temporary memory permanently stores data such as the Condition Based Service version, the vehicle identification number (VIN), software version, etc.

The Car Access System receives current data from the electrical system, such as outside temperature, engine temperature, date, time and odometer reading, via the K-CAN2.

The Car Access System collects that information. Under certain conditions, the data is transferred to the ID transmitter. In that way, the service key data is kept up to date for readout when the vehicle is taken in for servicing.

## Updating Service Data

The service data records and fault memory entries are collected in a temporary memory by the CAS. The service data is thus available from a central point.

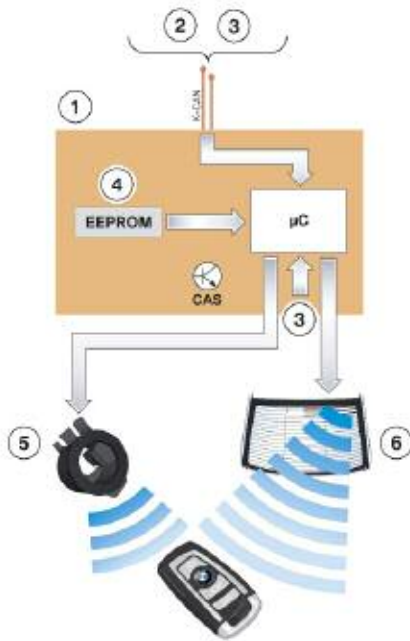

Index	Explanation
1	Car Access System
2	Current data on electrical system that CAS receives via K-CAN 2.
3	Diagnosis data via K-CAN2 or direct from Car Access System
4	Permanently stored data provided by Car Access System
5	Manual data transfer (emergency start coil, low frequency)
6	Automatic updating of data (transmission frequency of ID transmitter, high frequency)
µC	Accumulated data in Car Access System's temporary memory

If one of the conditions set out below results in transfer of the service key data, the service key data on the ID transmitter is updated.

Updating can be performed both by way of the emergency start coil's low frequency signal (5) and by means of the transmission frequency used by the ID transmitter (6).

## Updating Service Key Data

The service key data is stored in the Car Access System and transferred to the ID transmitter. Transfer is initiated automatically by specific conditions or manually. The data can be read out using the BMW Key Reader when the vehicle is serviced.



Index	Explanation
1	Key symbol
2	Updating service data
3	Symbol

### Automatic Updating

The service key data is updated every time the vehicle is driven. That data comprises:

- Condition Based Service data
- Check Control messages
- Fault memory entries.

The conditions for updating are:

- "Terminal 15 ON", speed above 25 mph followed by speed below 25 mph.
- The data is updated once a distance of 5 miles has been covered and the speed is below 25 mph.
- The remote control receiver transfers the data to the ID transmitter when the engine is switched off. Data continues to be written to the ID transmitter even after it is taken out of the vehicle.
- A data read-out can then be obtained from the ID transmitter.

### ■ Manual Updating

The procedure for transferring current service key data to the ID transmitter in the course of servicing is as follows:

- Press and hold the Center-Lock button and use the START-STOP button to select "Terminal 15 ON", then release both buttons.
- Within 10 seconds, hold the ID transmitter against the right-hand side of the steering column trim in the position marked by the key symbol.

The key symbol is printed on the steering column trim. Wait until the Check Control message appears on the instrument cluster. The instrument cluster display shows the message "Updating service data".

- As soon as the updating process is complete, the Check Control message disappears and a gong sounds.
- Data can then be obtained from the ID transmitter.

The manual updating process transfers Condition Based Service data, Check Control messages and fault memory entries.

### Control Unit Replacement

A defect in the control units belonging to the EWS represents a challenge for the Service technician. Since a defective control module cannot be replaced by control modules from other vehicles particular care is necessary when performing the diagnostic procedure.

A defective control unit can be ordered through spare part channels. However, it is important to bear in mind that the digital motor electronics and the Car Access System 4 are supplied ready-coded for the vehicle.

This has the advantage that only the control unit is replaced and the matching procedure with the electronic vehicle immobilizer is not necessary.

There is no point in ordering a control unit to be kept in stock as the secret key is assigned to the control unit and the vehicle.

A matching procedure is necessary for the electronic transmission control after replacement. As part of this procedure, the Car Access System 4 transfers the individual code to the electronic transmission control.

The matching procedure can take several minutes.



---

NOTES

PAGE

# Electronic Systems

## Comfort Access System

The F01/F02 will have Comfort Access as an option from the start of series production. It is part of the “Convenience Package”.

The Comfort Access in the F01/F02 is based on preceding systems and is adapted to the F01/F02. The following points should be noted:

- The entire function of Comfort Access is now located in the CAS 4.
- There is no separate control unit for Comfort Access in the F01/F02, in contrast to previous systems.
- Passive Go is standard equipment as there is no slot for the ID transmitter.
- The ID transmitter must be located in the vehicle interior in order for the engine to be started. The engine can now be started by pressing the START-STOP button and the vehicle is ready to be driven.

Comfort Access includes the following functions:

- Passive Entry, enables access to the vehicle without active use of the ID transmitter.
- Passive Go, the Passive Go function allows the vehicle to be started when a valid ID transmitter is located in the passenger compartment. (This is a standard feature in F01/F02)
- Passive Exit, makes it possible to lock the vehicle without actively using the ID transmitter.

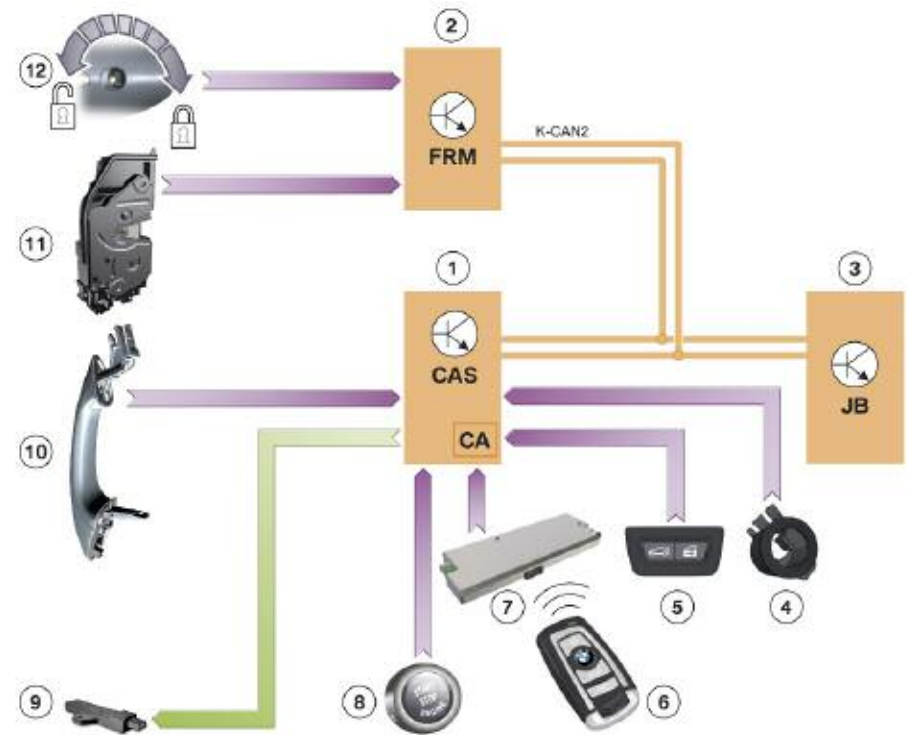

Index	Explanation	Index	Explanation
1	CAS 4	8	START-STOP button
2	FRM	9	Antenna for comfort access
3	Junction box electronics	10	Outside door handle electronics
4	Emergency start coil	11	Lock with door contact
5	Central locking button	12	Driver's door lock cylinder
6	ID Transmitter	CA	Comfort Access
7	Diversity module		

An ID transmitter comprises, among other things:

- A battery
- Remote control function
- Transponder coil for emergency start function
- Mechanical key
- Receiver unit.

The driver's door can also be unlocked and opened or closed and locked with the wallet key.

### Component Location Overview

The Car Access System is located above the steering column on the right-hand side. For the Comfort Access function, the Car Access System controls the transmitting antennas for the vehicle exterior and interior. The outside door handle electronics are also read by the Car Access System.



Index	Explanation	Index	Explanation
1	CAS 4 (with Comfort Access)	5	Central Gateway Module
2	Junction Box Electronics	6	Outside door handle electronics
3	Remote control receiver with diversity module	7	Antennas for Comfort Access (in yellow)
4	Footwell Module	8	Central locking components in the trunk

### Location of Antennas

For Comfort Access, 5 antennas are installed for the vehicle interior and 3 antennas are installed for the vehicle exterior.

The antennas for the exterior are installed in the door sills on each side of the vehicle.

The antenna for the rear of the vehicle is located in the bumper. The exterior antennas are designed to give a coverage area of 1.5 meters (about 5 feet).

The outside door handle electronics provide the Car Access System with the signal from the capacitive sensor and the piezo sensor.

As far as the 5 interior antennas are concerned, there are 2 in the luggage compartment and 1 in the parcel shelf. One is located in the front of the center console and one in the rear of the console.

The transmission frequency for the antennas is 125 kHz. All messages sent are encrypted.

**Note: For more information on Comfort Access, refer to the available reference material on ICP under course code ST811.**

## Central Locking

The Central Locking system on the F01/F02 is carried over from previous systems such as the E90 and E70. The following points should be noted:

- The CAS 4 has overall control of central locking
- The Comfort Access features are integrated into the CAS
- The JB executes the commands for central locking
- Soft Close Automatic (SCA) is part of the optional convenience package
- The soft close feature for the trunk is standard equipment

Various central locking functions can be operated via the following components:

- ID transmitter
- Driver's-door lock cylinder
- Center-lock button (in dash panel by hazard flasher switch)
- Trunk lock cylinder
- Exterior trunk release button
- Interior trunk release button in the A-pillar
- Outside door handle (outside door handle electronics/Car Access System)
- Central locking button in the trunk (w/comfort access)

## Input/Output Central Locking

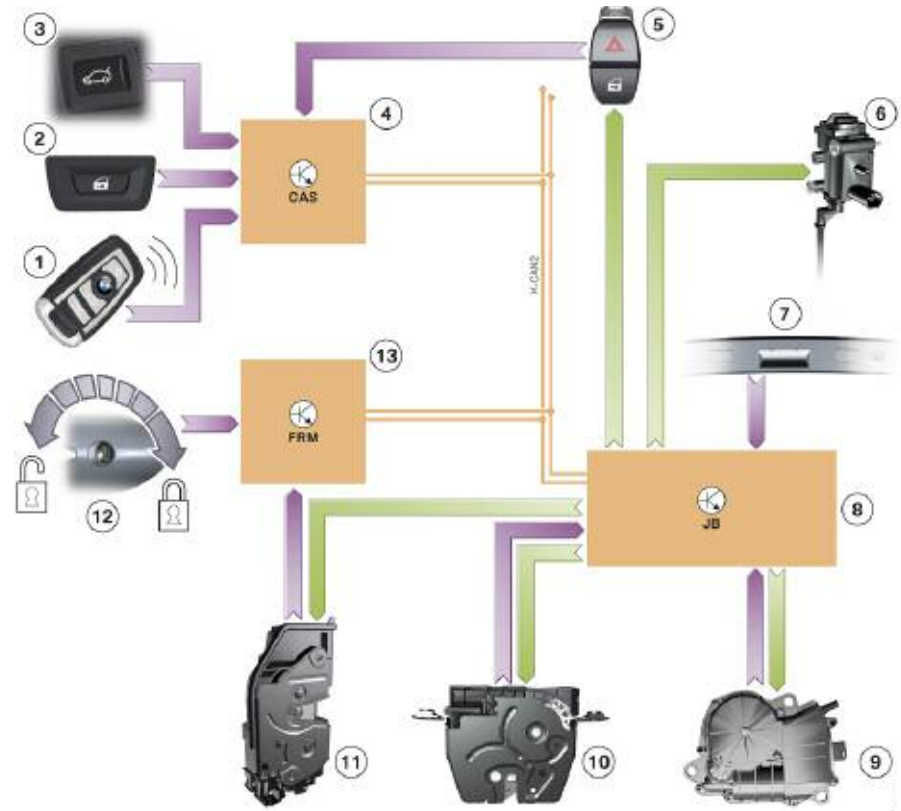

Index	Explanation	Index	Explanation
1	ID transmitter	8	Junction box electronics
2	Central locking button ( in trunk)	9	SCA drive unit for trunk lid
3	Trunk release button (A-pillar)	10	Trunk lock actuator
4	CAS 4	11	Lock actuator (4x)
5	Center-lock button	12	Driver's door lock cylinder
6	Central locking actuator, fuel filler flap	13	Footwell module
7	Exterior trunk release button		

## Operation of Central Locking

The Car Access System (4) evaluates the signal from the ID transmitter (1) and requests the unlocking or locking of the vehicle.

The junction-box electronics module (8) executes the requests.

The lock cylinder (12) in the driver's door is used for mechanically unlocking or locking the door.

The footwell module (10) evaluates the movement (status of Hall sensors) of the lock cylinder and the status of the door contacts.

The radio signal from the ID transmitter is received by the rear window antenna. The remote control receiver integrated in the diversity module (19) forwards the signal to the CAS (2).

After the signal has been successfully checked, the CAS issues a request for control of the central locking system. The CAS is the master control unit for the central locking system.

The junction-box electronics module (4) executes the unlocking or locking of the vehicle.

The footwell module (1) evaluates the status of all door contacts (6, 8, 14 and 16). It communicates the current status on the K-CAN 2.

This means, for example, that the CAS is able to prevent locking when the driver's door is open. The status of the center-lock button (3) is evaluated by the CAS and communicated over the K-CAN 2.

Depending on the status, the JB electronics module activates central locking. The junction-box electronics modules is also responsible for registering the status and activating central locking in the trunk.

The junction-box electronics module is also responsible for controlling the fuel filler flap (10). The footwell module evaluates the signals from the Hall sensors for the lock cylinder (16) and makes this information available on the K-CAN2.

With this information, the CAS knows the status of the door lock in the driver's door. This is important if a request is issued to unlock or lock the vehicle using the ID transmitter, for example.

The central locking button is integrated in the underside of the trunk lid and is part of the Comfort Access option.

### ■ K-CAN 2 signals at CAS 4

In/Out	Information	Source/	Function
In	Crash signal	Crash sensor>ACSM	Unlock central locking in the event of a crash
In	Driving speed	Wheel speed sensor>ICM	Lock central locking at a defined driving speed
Out	Hall sensor status, driver's door lock cylinder	Driver's door lock cylinder>FRM	Comfort opening of the vehicle
Out	Hall sensor status, driver's door lock cylinder	Driver's door lock cylinder>FRM	Comfort closing of the vehicle

**Note: For more information on Central Locking, access the available reference material on ICP under course code ST811.**

## Power Windows

The F01/F02 is fitted with electric power windows. The electric power windows have the following functions:

- One-touch opening and closing
- Toll opening and closing
- Auto-remote opening and closing.

The CAS 4 is the central control function for electric opening and closing of the windows.

The FRM and JB electronics are responsible for the execution and activation of the power window motors.

The footwell module and the junction box electronics monitor the motor speed of the respective power window motors.

In this arrangement, the FRM or JB electronics can respond to overheating or possible blocking of the power window motors in the event of an object being trapped in the windows.

The signal from the power window switch can pass through different bus systems until the desired window is opened or closed.

### Activation Example

The driver's door switch block is connected via the LIN bus to the FRM. The signal is routed via the LIN bus to the FRM when the power window switch for the window in the passenger's door is operated.

The FRM drives the power window motor. The same applies for the window in the driver's door.

The signal is routed from the driver's door switch cluster via the LIN bus to the FRM when the power window switches for the windows in the rear doors are operated. The FRM sends the signal via the K-CAN to the JB electronics. The JB electronics receives the signal and activates the corresponding power window motor.

### Input/Output Power Windows

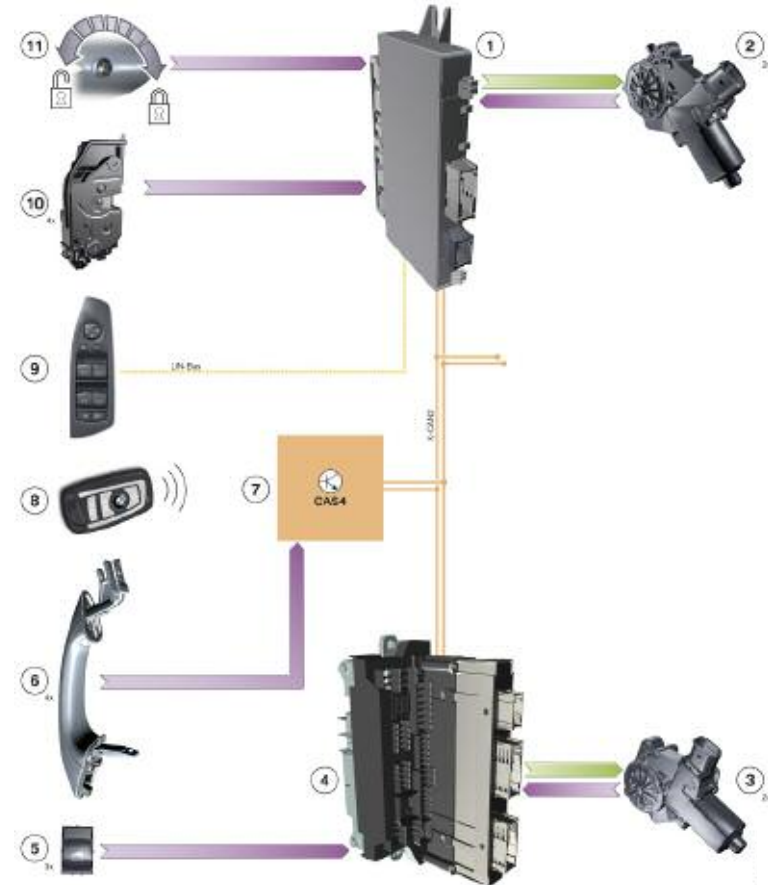

Index	Explanation	Index	Explanation
1	FRM	7	CAS 4
2	Power window motor, front doors	8	ID transmitter
3	Power window motor, rear doors	9	Driver's door switch cluster
4	Junction box electronics	10	Lock actuator w/door contact
5	Power window switch, passenger's front and rear (L and R)	11	Lock cylinder, driver's door
6	Outside door handle (Comfort Access)		

## Power Window Operation

The Car Access System (2) issues the enable to actuate the power window motors (5, 7, 12 and 14).

If a power window switch is then activated, the FRM (1) (front power window motor) or the JB electronics (3) (rear power window motor) executes the request.

## Examples of the Signal Path

The following examples of a signal path show the path taken by the signal before the power window motor opens or closes the window. The CAS 4 has issued the enable to operate the power windows.

### ■ Driver's door switch cluster

When the power window switch for the window in the driver's door or front passenger's door is operated, the signal is routed via the LIN bus to the FRM. The FRM drives the corresponding power window motor.

The signal is routed from the driver's door switch cluster via the LIN bus to the FRM when the power window switches for the windows in the rear doors are operated.

The FRM sends the signal via the K-CAN 2 to the JB electronics. The JB electronics receives the signal and activates the corresponding power window motor.

### ■ Power window switch, front passenger's door

The signal is routed to the JB electronics when the power window switch in the front passenger's door is operated.

The JB electronics sends the signal via the K-CAN2 to the footwell module. The FRM drives the power window motor.

### ■ Power window switch, rear doors

When the power window switches in the rear doors are operated, the signal is routed to the junction box electronics. The junction box electronics drives the power window motor.

By way of example, the opening and closing procedure for one of the rear windows is illustrated by the signal path in the following graphic. The opening or closing function is initiated from the driver's door switch cluster.

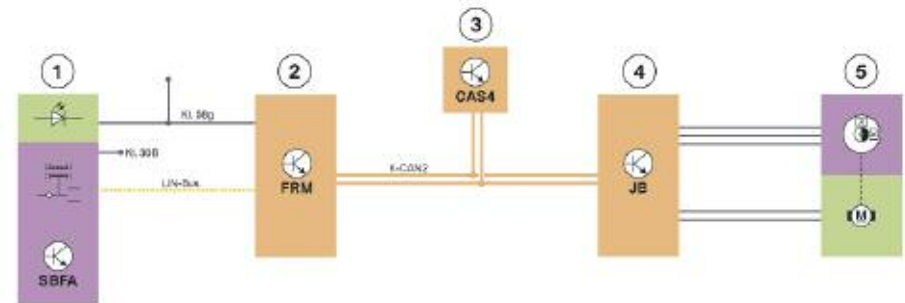

Index	Explanation
1	Power window switch, driver's door (SBFA)
2	Footwell Module (FRM)
3	Car Access System 4 (CAS 4)
4	Junction Box electronics (JB)
5	Power window motor

**Note: For more information on Power Windows, access the available reference material on ICP under course code ST811.**



## Sliding/Tilting Sunroof

The slide/tilt sunroof is standard on the F01/F02. Several control units are involved in the operation of the slide/tilt sunroof.

The following points should be noted:

- The sunroof utilizes 2 motors, one for the glass and one for the shade
- The FZD controls and monitors both motors for the sunroof
- The CAS communicates with the FZD for sunroof operation via the central locking system
- The FRM supplies the signal from the door contacts.
- The Junction Box electronics provide the power supply for the motors via terminal 30.
- The DSC acquires the signals from the wheel speed sensors while the ICM makes available the speed signal to the vehicle electrical system for the operation of the wind deflector.

### Slide/tilt Sunroof Operating Concept

The button for operating the slide/tilt sunroof has three directions of movement. In addition to the manual and overpress functions, the button has a double-click function in the three movement directions:

- Manual, means opening or closing until the button is released.
- Overpress function, means opening or closing using the one-touch control function
- Double-click function, means that the button is pressed twice within a short time into the overpress position or into the tilt position. This enables the slide/tilt sunroof to be opened and closed automatically from any position.

While moving, the slide/tilt sunroof can be stopped by pressing the button in the opposite direction.

### Input/Output Sliding/tilting Sunroof

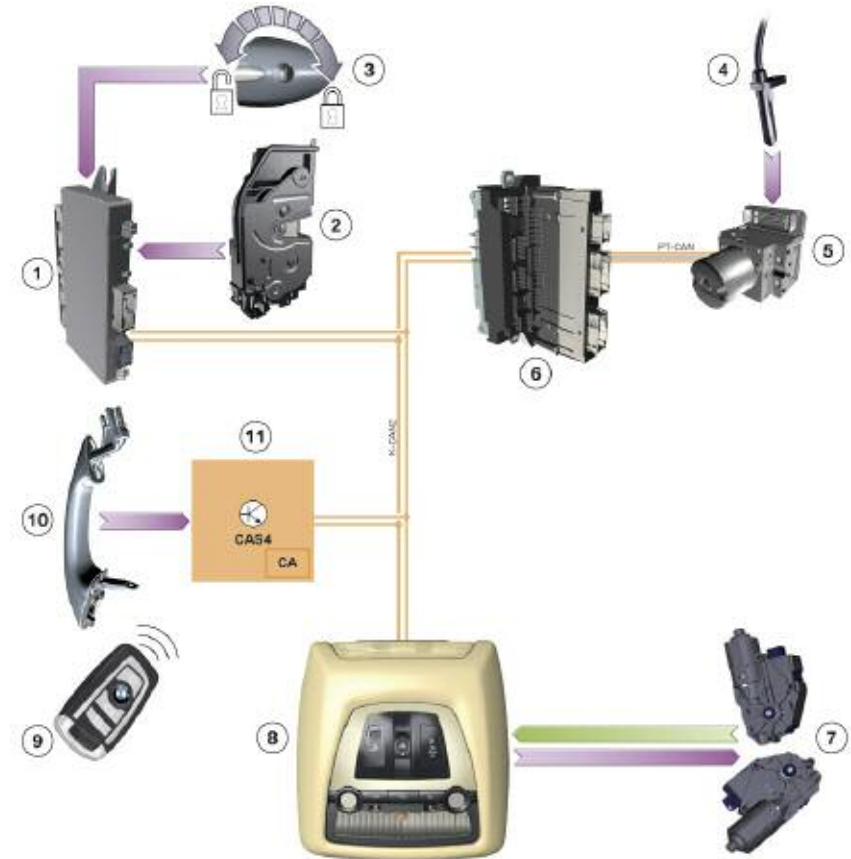

Index	Explanation	Index	Explanation
1	Footwell module (FRM)	7	Slide/tilt sunroof motors
2	Door contacts (4x)	8	Roof Functions Center (FZD)
3	Lock cylinder, driver's door	9	ID transmitter
4	Wheel speed sensor	10	Outer door handles, driver and passenger
5	Dynamic Stability Control	11	CAS 4
6	Junction Box Electronics		



## System Diagram

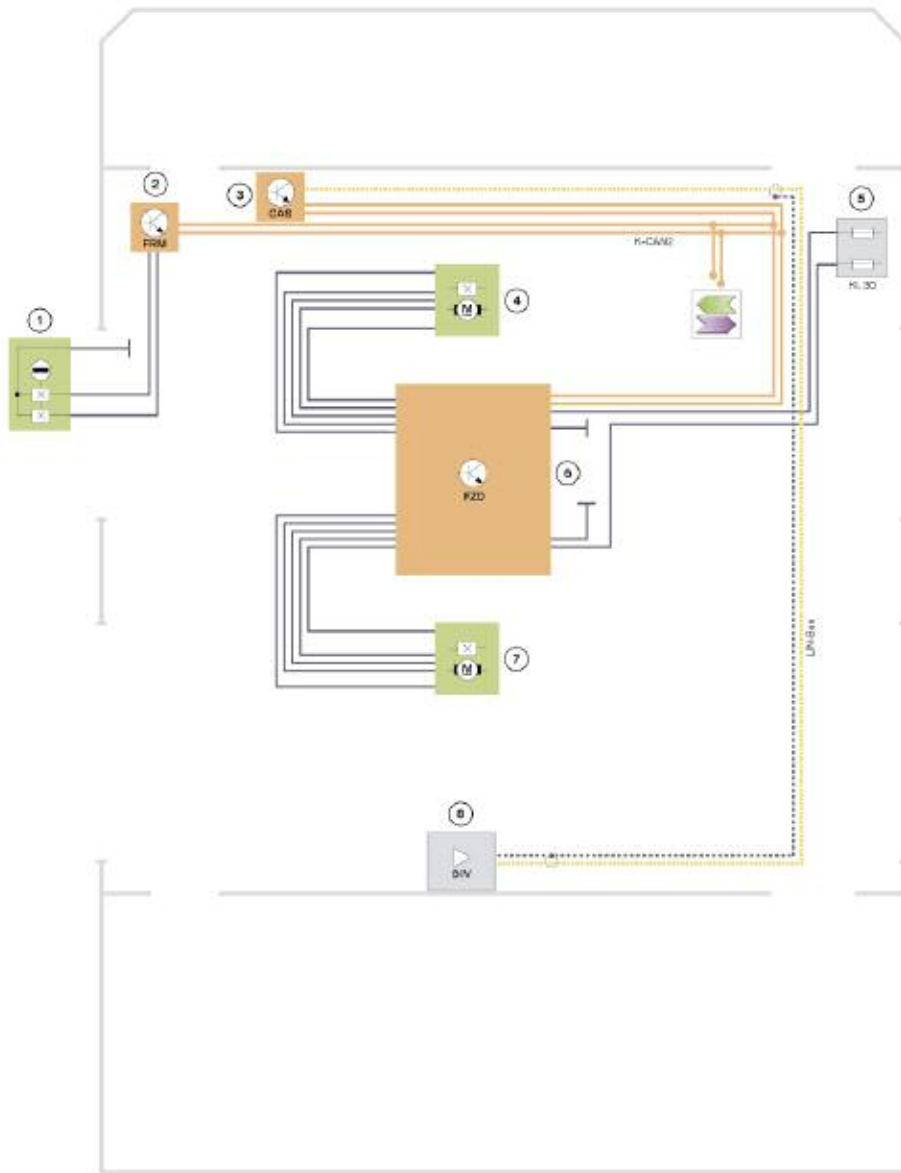

Index	Explanation	Index	Explanation
1	Hall sensors, driver's door lock cylinder	5	Front power distribution box
2	Footwell module (FRM)	6	Roof Functions Center (FZD), with sunroof button
3	Car Access System 4 (CAS 4)	7	Slide/tilt sunroof motor
4	Slide/tilt sunroof motor	8	Remote control receiver in diversity module

### K-CAN 2 Signals at FZD

In/Out	Information	Source	Function
In	Vehicle speed	Wheel speed sensor > DSC > ICM	Release wind deflector
In	Outside temp	Outside temp sensor > cluster	Info used in determination of overheating protection for the window motors
In	Slide/tilt enable	CAS 4 > FZD	Enable for slide/tilt sunroof operation
In	KL 50 Status	CAS 4 > FZD	Interruption in sunroof operation during cranking
In	Auto-remote opening	ID transmitter > CAS 4	Slide/tilt sunroof auto-remote opening
In	Auto-remote opening	Driver's door lock cylinder > FRM	Slide/tilt sunroof auto-remote opening
In	Auto-remote closing	Driver's door lock cylinder > FRM	Slide/tilt sunroof auto-remote closing
In	Auto-remote closing	Outer door handle > comfort access	Slide/tilt sunroof auto-remote closing
Out	Anti-trap function deactivated	FZD > Kombi	Anti-trapping function indicator deactivated

## Alarm System (DWA)

The DWA system is standard equipment in the F01 and F02 and is functionally the same as previous models.

There are a few points to note:

- The ultrasonic interior sensor is entirely integrated in the roof function center (FZD).
- The emergency power siren and combined tilt sensor is located near the rear wheel arch.
- It is not possible to activate the alarm system when the Terminal R or Terminal 15 signal is present.

### Overview

The anti-theft alarm system is a standard feature. The task of the anti-theft alarm system is to indicate unauthorized access to the vehicle by emitting an alarm.

The alarm can be triggered both audibly and visually. To do this, however, the alarm system must be activated. When activated, the alarm monitors the whole of the vehicle interior.

In addition the alarm system monitors the engine compartment and the vehicle's rest position. In order that nothing can be stolen from the trunk, the alarm system monitors opening of the trunk lid.

The alarm also signals an attempt to tamper with the vehicle, e.g. cutting of the supply line to the emergency power siren.

The alarm system's ultrasonic interior movement detector is entirely integrated in the roof function center (FZD).

The ultrasonic signal passes into the inside of vehicle through apertures in the grille of the roof function center. The emergency power siren and combined tilt sensor is located near the rear wheel arch.

## Alarm System Schematic

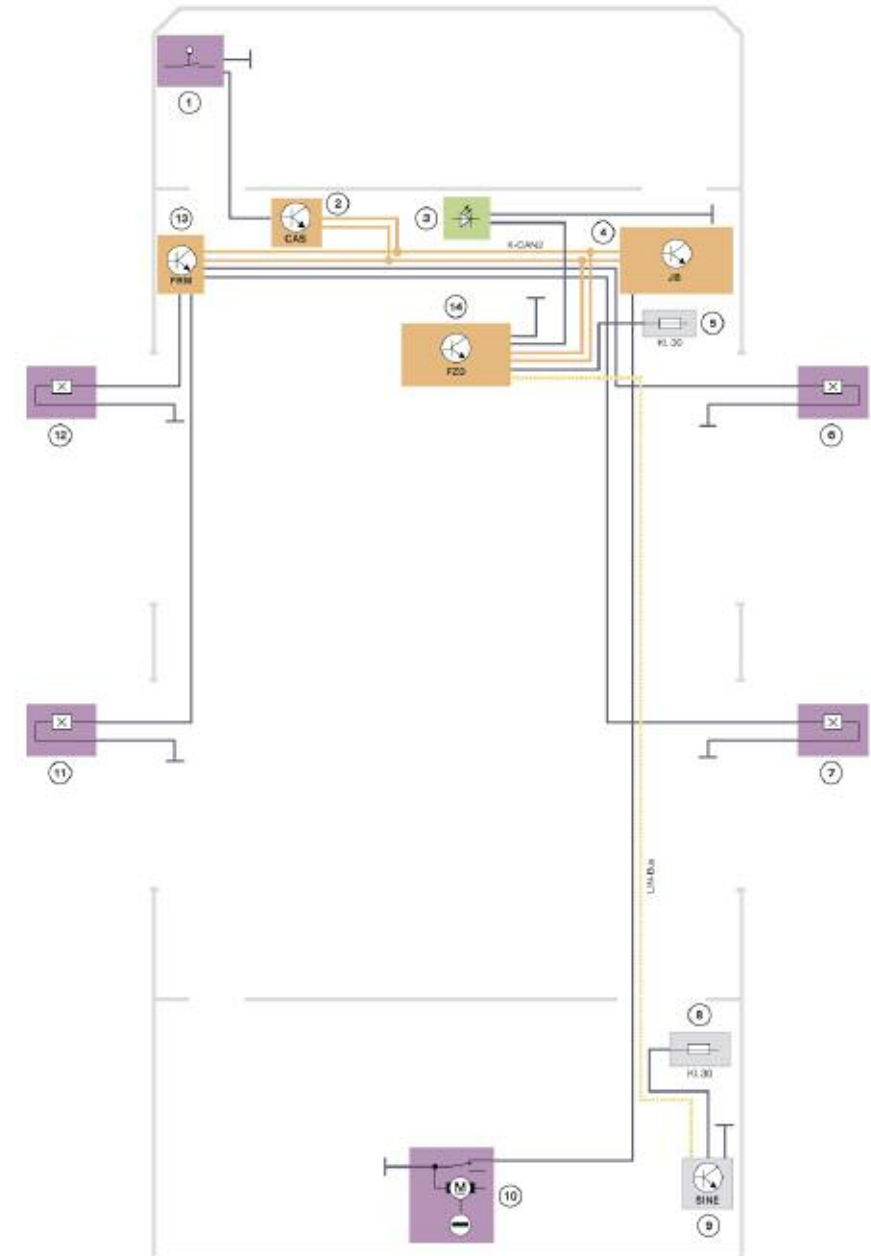

## Legend for Alarm System Schematic

Index	Explanation	Index	Explanation
1	Hood switch	9	Siren with integrated tilt sensor
2	Car Access System 4	10	Trunk lock with trunk lid switch
3	DWA LED	11	Door contact, rear driver's side door
4	Junction box electronics	12	Door contact, driver's door
5	Front power distribution box	13	Footwell Module (FRM)
6	Door contact, passenger door	14	FZD with integrated USIS
7	Door contact, rear passenger door	KL 30	Terminal 30
8	Rear power distribution box		

The alarm system on the F01/F02 uses an ultrasonic interior movement detector (USIS) for monitoring the vehicle interior. The USIS is fully integrated in the FZD.

The door switches (6, 7, 11, 12, Hall-effect sensors) are monitored by the FRM (13). As soon as the status of a Hall-effect sensor changes, the ultrasonic interior movement detector (14) receives that information via the K-CAN2. If the DWA system is activated, an alarm is triggered.

The hood switch (1) is monitored by the CAS 4 (2). If the status changes, an alarm is triggered in the same way. Opening of the trunk lid is monitored by the JB electronics (4). If the status of the trunk-lid switch (10) changes, it triggers an alarm.

## Activating the Anti-theft Alarm

The anti-theft alarm system is activated when the vehicle is centrally locked. Activation can be triggered by the following components:

- Driver's door lock barrel
- ID transmitter
- Outside door handle with Comfort Access (sensitive surface).

After the vehicle has been centrally locked, the emergency power siren is first activated together with the tilt alarm sensor. Then, the signals from all door switches, the hood switch and the trunk-lid switch are checked for plausibility.

Once the contacts are set, they are then linked to the vehicle monitoring system by the anti-theft alarm system.

The tilt sensor and the ultrasonic interior movement detector must be adjusted to the vehicle's situation each time the vehicle is centrally double-locked. This is called initializing.

The tilt alarm sensor delivers information on the vehicle's rest position. If this value is plausible, the tilt alarm sensor is included in the vehicle monitoring process.

The alarm system's ultrasonic interior movement detector monitors the passenger compartment. It therefore takes a little time before the ultrasonic interior movement detector can actively be used for the anti-theft alarm system. The ultrasonic interior movement detector is switched to 'activated' approximately 30 seconds after the contacts have been linked to the alarm system.

### ■ Deactivating tilt sensor and ultrasonic interior sensor (USIS)

It is advisable to deactivate the tilt sensor and USIS in the following situations:

- Vehicle parked on slanted surface
- Vehicle on ship transport
- Vehicle on car transporter
- Persons or animals in vehicle.

Deactivation is performed by centrally double-locking or auto-remote closing the vehicle a second time within 10 seconds of doing so the first time. To acknowledge, the alarm system LED is lit for 2 seconds.

### ■ Deactivating the anti-theft alarm system

The anti-theft alarm system is deactivated by the "unlock" or "selective unlock" central locking functions. An audible and/or visual signal can be output in connection with deactivating corresponding to the country specific version.

If an alarm was triggered during the time when the anti-theft alarm system was activated, the alarm system LED flashes for 5 minutes. If a terminal status changes, e.g. if the central locking is unlocked, while the LED is flashing then the LED stops flashing. If the alarm is deactivated while the alarm is active, the deactivate instruction is not acknowledged and the alarm signal is completed.

### ■ Unlocking the trunk

The tilt alarm sensor and USIS are blanked out if the luggage compartment is unlocked and opened on an armed vehicle. Loading the vehicle might result in a new vehicle resting position.

Initialization of the USIS and the tilt sensor starts 6 seconds after the trunk is closed again. When the trunk is closed, the visual confirmation signal is repeated to indicate to the driver that the trunk properly closed.

### ■ No crosswise operation

If crosswise operation is not implemented, an alarm is triggered when the anti-theft alarm system is deactivated.

This only applies to activating with the ID transmitter and deactivating via the driver's door lock. The footwell module detects that the vehicle has been unlocked via the driver's door lock and broadcasts that information via the K-CAN 2.

The CAS detects that the driver's door lock has been unlocked but does not unlock the vehicle. The anti-theft alarm system remains activated and triggers the alarm when the driver's door is opened.

This function is coded on the Car Access System.

### Alarm System Feedback

When the alarm is activated, the system does not signal confirmation until all doors, the hood and the trunk have been closed. That confirmation may be in the form of a visual or audible signal.

If confirmation is by a visual signal, the alarm LED or the hazard warning lights may flash. If the confirmation signal is audible, it is produced by sounding the emergency power siren.

### ■ Feedback via DWA LED

The DWA LED serves as an indicator showing the status of the DWA system. The FZD supplies the DWA LED with signals from the USIS.

When blinking, the DWA LED is driven at a frequency of 0.5 Hz. The switch-on time is 60 milliseconds. When the DWA LED flashes, it is activated at a frequency of 2 Hz.

DWA Status	DWA LED
Deactivated	OFF
Activated	ON
Armed, but not all contacts closed	Blinks for 10 seconds, then continues flashing
Ultrasonic interior motion/tilt sensor OFF	Lights up for 2 seconds and then remains on
Alarm triggered	Flashes for 5 minutes, then continues flashing in bursts
Deactivating	Goes out
Deactivating after alarm	Flashes for 5 minutes or stops if a terminal status changes (central locking unlocked)

#### ■ Confirmation from turn signal indicators

Visual confirmation by the turn signal indicators of alarm system activation and deactivation serves as an indication for the vehicle user.

DWA Status	Signal of hazard warning lights
Activation	Hazard warning lights flash once
Deactivation	Hazard warning lights flash twice
Activation after "Easy Access" to trunk	Hazard warning lights flash once after trunk is closed
Deactivating after alarm	Hazard warning lights flash four times at double frequency

#### ■ Confirmation via the emergency power siren

There is an audible confirmation signal to the vehicle user when activating and deactivating the alarm.

DWA Status	Signal from siren
Activation	Signal tone sounds once
Deactivation	Signal tone sounds twice
Activation with doors open or trunk lid open	No signal tone, sounds only after closing last door or trunk lid

#### ■ Comfort Access

If the vehicle is locked but the trunk is open, it is possible for the ID transmitter to be inadvertently left in the luggage compartment. If the trunk lid is closed in such circumstances, it is automatically opened again to prevent the ID transmitter from being locked in.

In addition to automatically opening the trunk lid, the alarm system emits an audible warning. The warning consists of the emergency power siren sounding a two-tone signal three times.

The FRM also activates the visual signal by the hazard warning lights.

**Note: For more information on the DWA system, access the available reference material on ICP under course code ST811.**

## Windshield Wiping/Washing

The wiper/washer system for the F01 operates much the same as previous models. The functions of the windshield wiping includes the following functions:

- Intermittent wipe in stages
- Automatic wipe using the rain/light/solar/condensation sensor
- Continuous wipe, stage 1
- Continuous wipe, stage 2
- Flick wipe.

The following systems are also included:

- Headlight washer system SA 502
- Water jet heater

The wiper motor for the wiper/washer system is connected via a LIN bus.

### Automatic Wipe

The automatic wipe function is activated by pressing the axial button at status "terminal R ON". The LED on the wiper switch indicates that the function is active. A single wipe cycle is additionally started.

The rain/lights/solar/condensation sensor initiates wipe requests according to the heaviness of the rain. The junction box control unit requests the status of the rain/lights/solar/condensation sensor via the LIN bus. The junction box electronics monitor the function of the wiper motor via the LIN bus.

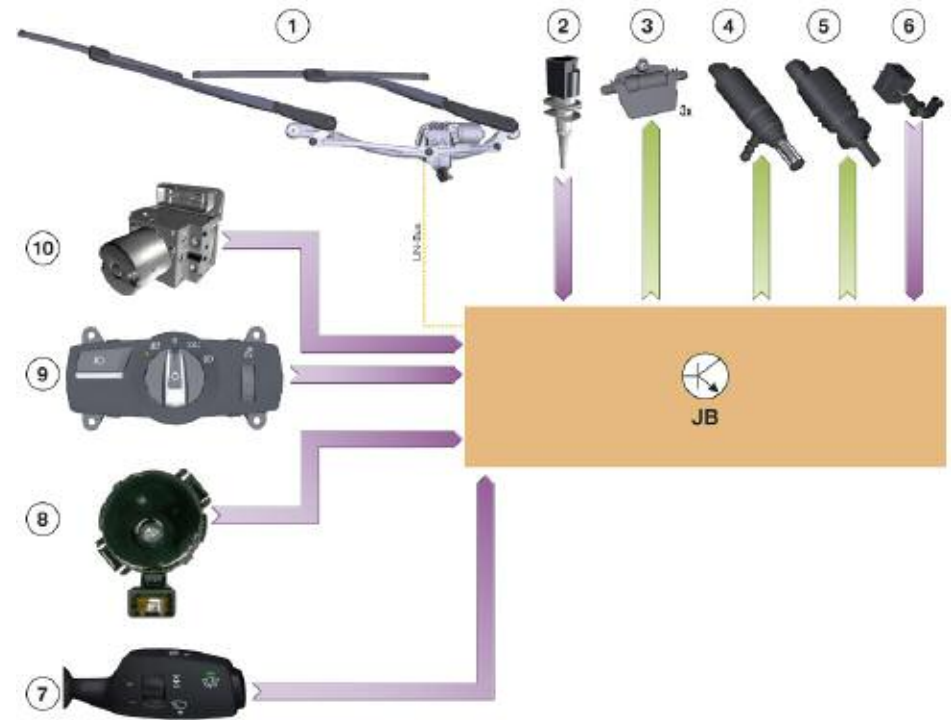

Index	Explanation	Index	Explanation
1	Wiper motor with wiper linkage	7	Wiper switch on steering column stalk
2	Outside temperature sensor	8	Rain/lights/solar/condensation sensor
3	Heated washer jets (3x)	9	Light switch
4	Headlight washer system motor	10	Dynamic stability control
5	Washer fluid pump motor	JB	Junction box electronics
6	Washer fluid level sensor		

## Components

The following components are involved in the wiper/washer system:

- Control units
  - Steering column switch cluster
  - Central gateway module
  - Junction box electronics
  - Instrument cluster
  - Dynamic stability control
- Rain/lights/solar/condensation sensor
- Wiper switch on the steering column stalk
- Relay for headlight washer system
- Wiper motor
- Pump for the front washer fluid
- Pump for headlight washer system
- Heated washer jets.

### ■ Steering column switch cluster

The steering column switch cluster evaluates the status of the wiper switch on the steering column stalk. The respective status is issued by the steering column switch cluster on the FlexRay.

### ■ Junction box electronics

The junction box electronics is the central control unit for all wipe and wash functions. The junction box electronics communicate the current wipe requirement via the LIN bus.

This request is received by the electronics in the wiper motor and the relevant wiper stage is initiated.

A separate relay is fitted in the front distribution box for the headlight washer system.

### ■ Dynamic stability control

The Dynamic Stability Control provides the road speed signal.

### ■ Rain/lights/solar/condensation sensor

The rain/lights/solar/condensation sensor is the same as the rain/driving lights/solar sensor, but has been enhanced with the condensation sensor function.

The functionality of the rain sensor, the driving lights sensor and the solar sensor have been retained in full.

The driving lights sensor supplies the on and off signal for the automatic driving lights control function.

The solar sensor makes sure the automatic climate control system provides optimum air conditioning distribution in the vehicle.

The condensation sensor allows the integrated automatic heating/air-conditioning system to detect when condensation is forming on the windscreen in good time, even before the driver is aware of it.



Index	Explanation
1	Rain, lights, solar sensor
2	Sensor for HUD
3	Condensation sensor

## System Circuit Diagram for Wiper/washer System

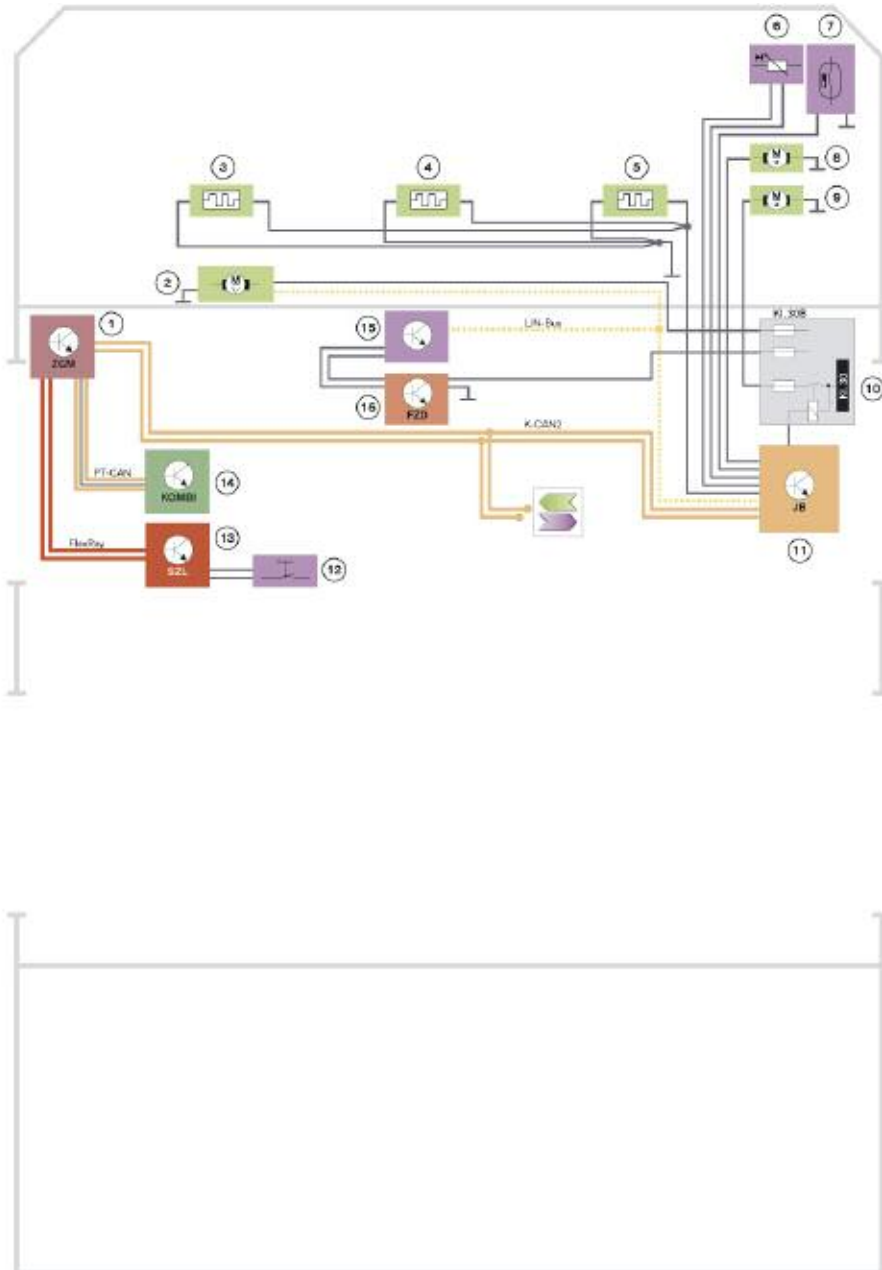

Index	Explanation	Index	Explanation
1	ZGM	10	Front distribution box
2	Wiper motor	11	Junction box electronics
3	Heated washer jet, driver's side	12	Wiper switch
4	Heated washer jet, center	13	SZL
5	Heated washer jet, passenger side	14	Instrument cluster
6	Outside temperature sensor	15	Rain/lights/solar/condensation sensor
7	Washer fluid level sensor	16	FZD
8	Washer fluid pump motor	KL30	Terminal 30
9	Motor, headlight washer	KL30B	Terminal 30 B (basic operation)

**Note:** For more information on the wiper system, access the available reference material on ICP under course code ST811.



---

NOTES

PAGE

## Outside Rear View Mirrors

For the F01/F02, there is one version for the outside mirrors. The outside mirrors feature a LIN bus connection with the following additional functions:

- Outside mirror fold-in
- Electrochromic outside mirrors
- Memory function of outside mirror settings
- In combination with the Lane Change Warning, the outside mirror also contains the LED for the Lane Change Warning display.

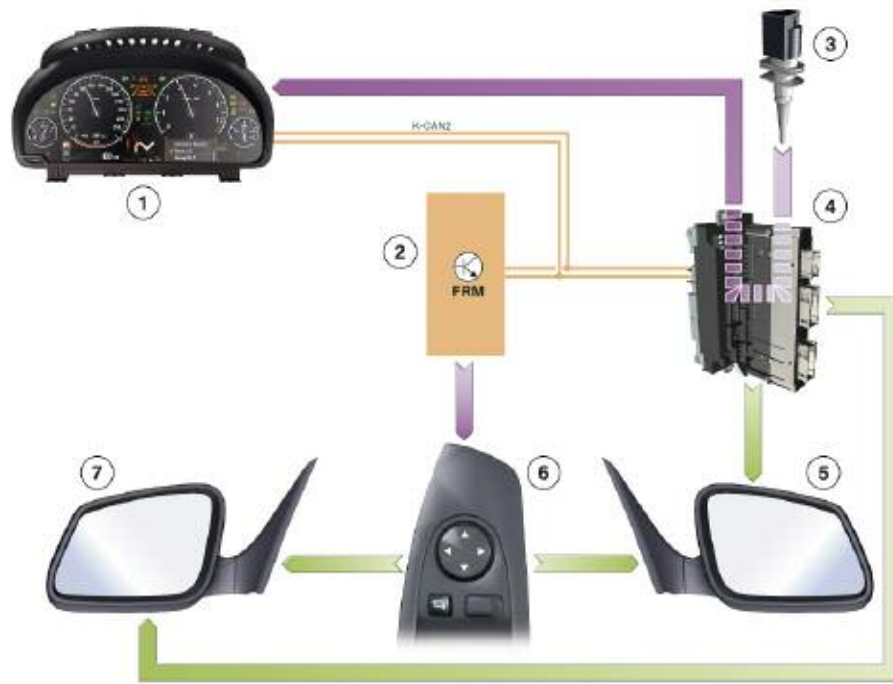

Instrument cluster (1) records the outside temperature and makes this information available to the vehicle electrical system.

In the F01, the footwell module (2) receives the outside temperature from the instrument cluster. The outside mirrors are connected via the LIN-bus. The footwell therefore requests the mirror heating function via the LIN-bus.

Index	Explanation	Index	Explanation
1	Instrument cluster	5	Outside mirror, driver's side
2	Footwell module (FRM)	6	Driver's door switch block
3	Outside temperature sensor	7	Outside mirror, passenger's side
4	Junction box electronics		

## Schematic, Outside Rear View Mirrors

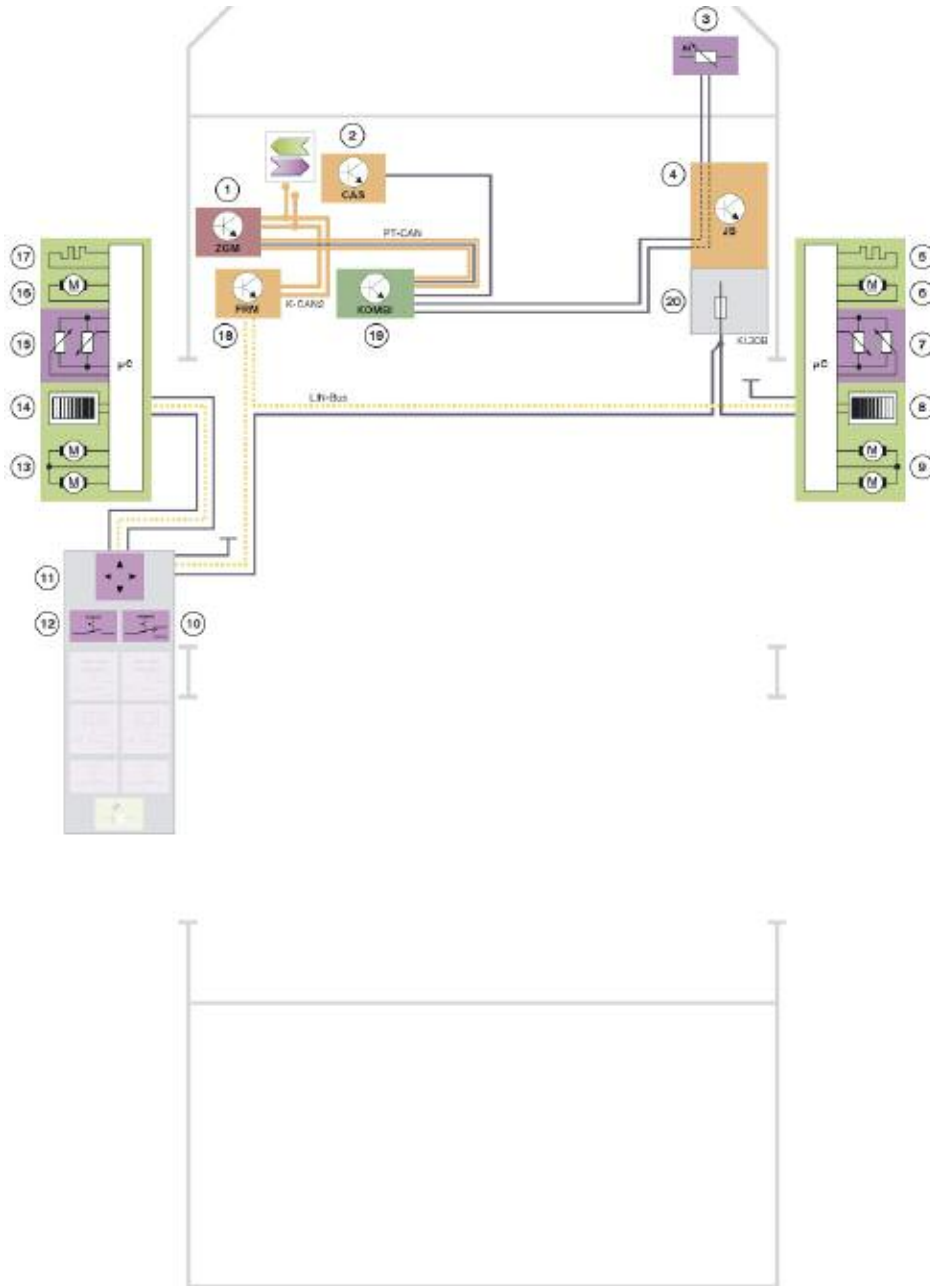

Index	Explanation	Index	Explanation
1	Central Gateway Module (ZGM)	14	Electrochromic outside mirror, driver's side
2	Car Access System 4 (CAS 4)	15	Memory, outside mirror potentiometer, driver's side
3	Outside temperature sensor	16	Motor for folding mirror function, driver's side
4	Junction box electronics (JB)	17	Outside mirror heating, driver's side
5	Outside mirror heating, passenger's side	18	Footwell Module (FRM)
6	Motor for folding mirror function, passenger's side	19	Instrument cluster
7	Memory, outside mirror potentiometer, passenger's side	20	Front distribution box
8	Electrochromic outside mirror, passenger's side	LIN-Bus	Local Interconnect Network bus
9	Actuator motor for passenger's side outside mirror	KI. 30B	Terminal 30 basic operation
10	Driver's door switch cluster (SBFA) with mirror selector switch	KI. 58g	Terminal 58g
11	Driver's door switch cluster (SBFA) with mirror adjustment switch	K-CAN2	Body CAN2
12	Driver's door switch cluster (SBFA) with mirror folding switch	PT-CAN	Powertrain CAN
13	Actuator motor for driver's outside mirror		

The instrument cluster (19) receives the value corresponding to the outside temperature from the outside temperature sensor (3) and makes it available via the PT-CAN.

The footwell module (18) evaluates the K-CAN2 signal and initiates activation of the outside mirror heating (5 and 17).

The mirror adjustment motors (9 and 13) are driven by the electronic mirror module. The electronic mirror module receives the request to adjust the outside mirrors via the LIN-bus.

The outside mirrors are connected via the LIN-bus. All information such as the memory position or mirror functions, e.g. dip outside mirrors, is transferred via the LIN-bus.

## Steering Column Switch Cluster

The steering column switch cluster is a "mechanical and electrical interface" from the steering wheel to the vehicle and is connected rigidly and mechanically to the steering column.

On top of this purely mechanical connection, the steering column switch cluster is connected electrically via bus systems or directly to components.

The steering column switch cluster has a steering column stalk on each side. The right hand steering column stalk is for activating/deactivating the wiper/washer-system functions.

The left-hand steering column stalk is for activating/deactivating the exterior lights (high beam/low beam) and for operating the on-board computer functions.



Index	Explanation	Index	Explanation
1	Turn signal/main-beam steering column stalk	5	Connection to horn button, LIN bus multifunction buttons and steering wheel electronics
2	Connection to the igniter pellets of the airbag	6	Vibration actuator power supply connection
3	Steering column switch cluster locking pin	7	Wiper switch on the steering column stalk
4	Steering wheel driver		

## Steering Wheel

The steering column switch cluster receives the button signals from the steering wheel either directly or on the LIN bus. These signals are forwarded by the steering column switch cluster.

The steering wheel contains a button block for the Dynamic Cruise Control DCC and Active Cruise Control ACC Stop & Go functions.

This button block is located on the left-hand side of the steering wheel. The steering column switch cluster broadcasts signals such as those from the radio volume control buttons on the PT-CAN.

The steering column switch cluster receives signals on the FlexRay, e.g. the signal for controlling the vibration actuator.



Index	Explanation	Index	Explanation
1	Steering wheel heating	4	Lane departure warning imbalance motor
2	Cruise control button block	5	Steering wheel electronics
3	Airbag unit	6	Radio/telephone button block

## ■ Schematic, SZL and Steering Wheel Electronics

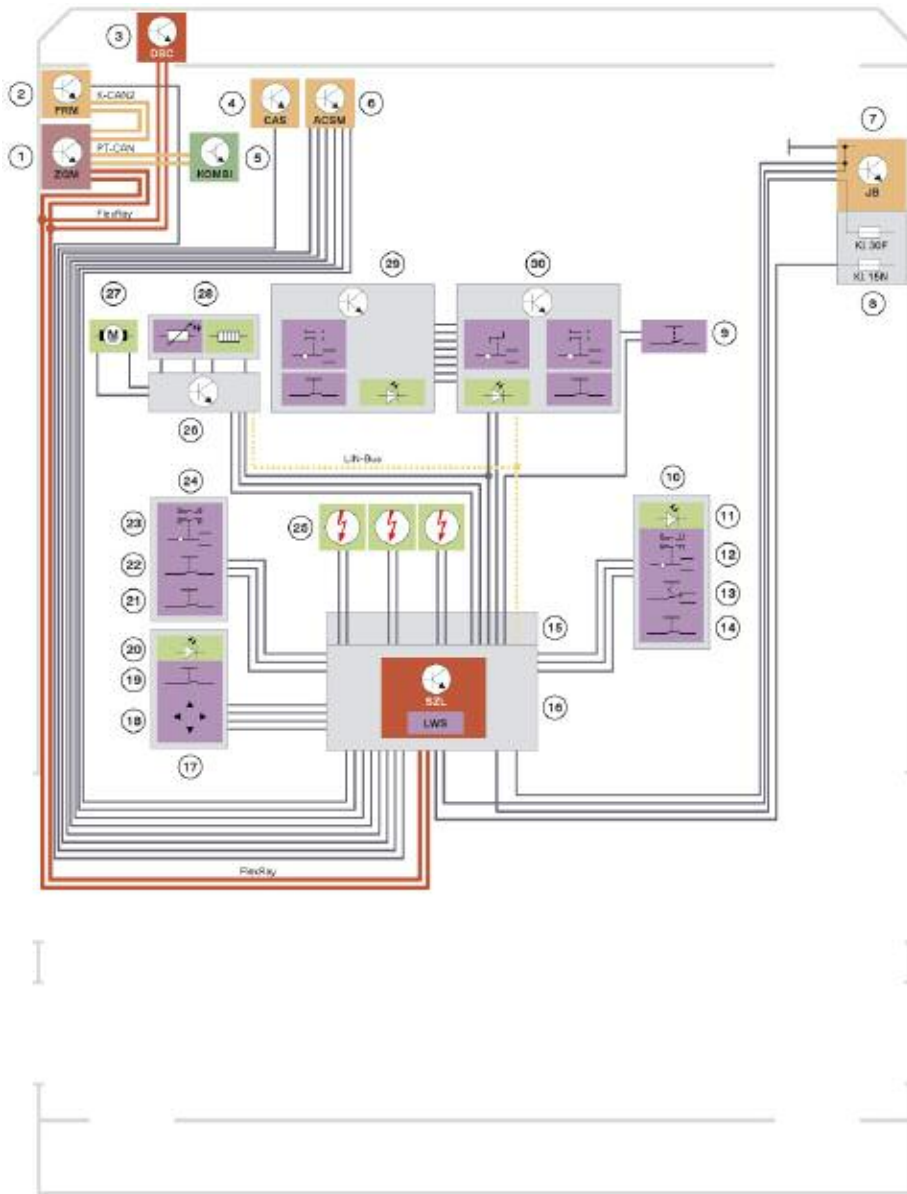

Index	Explanation	Index	Explanation
1	Central Gateway Module (ZGM)	16	Steering column switch cluster (SZL)
2	Footwell Module (FRM)	17	Button combination steering wheel heating adjustment/electrical steering column adjustment
3	Dynamic Stability Control (DSC)	18	Electrical steering column adjustment button
4	Car Access System 4 (CAS 4)	19	Steering wheel heating button
5	Instrument cluster (KOMBI)	20	Steering wheel heating button LED
6	Crash Safety Module (ACSM)	21	High-beam assistant button
7	Junction box electronics (JB)	22	On-board computer button
8	Front distribution box	23	Turn-indicator / high-beam switch
9	Fanfare-horn button	24	Steering column stalk for turn-indicator / high-beam switch
10	Steering column stalk wiper switch	25	Driver's airbag priming caps
11	Automatic wiping LED	26	Steering wheel electronics
12	Wiper switch	27	Vibration actuator
13	Knurled wheel for intensity of the rain-light-solar-condensation sensor	28	Steering wheel heating
14	Automatic wiping button	29	Button block for cruise control system in the multifunction steering wheel
15	Steering column switch cluster coil spring	30	Button block for radio/telephone etc. in the multifunction steering wheel

## Exterior Lighting System with Adaptive Headlights

The adaptive headlight AHL (with bi-xenon lights) is standard on the F01/F02. The adaptive headlights include the functions of the exterior lighting system. However it allows panning of the bi-xenon low-beam and high-beam headlights when cornering while driving.

Panning of the bi-xenon low-beam and high beam headlights is adapted continuously during cornering. Illumination during cornering therefore improves the driver's vision.

Illumination during cornering results in:

- Safer cornering with faster identification of obstacles
- Better perception of the environment
- Prevention of accidents.

The electronics of the adaptive headlight allow fast reaction to the current driving conditions. The system is controlled by the electronics and is less susceptible to malfunctions than purely mechanical systems.

### Overview

The functions of the exterior lighting are integrated in the footwell module. These lighting functions are:

- Side lights (parking lights)
- Low beam headlight
- High-beam headlight
  - Headlight flasher
- Fog light
- Direction indicator light
  - Hazard warning light
- Tail light/license plate light
- Brake force display

- Reversing light
- Parking lights
- Welcome light
- Delayed switch-off home lights
- Daytime driving light.

The headlight lighting functions are powered via a headlight driver module or the footwell module.

The footwell module controls a constant brightness level for each headlight. This is achieved with a pulse-width regulated voltage supply. Voltage fluctuations in the vehicle electrical and bus systems are compensated for by the pulse width.

The LEDs, e.g. in the additional brake light, tail light or bi-xenon headlight are not controlled but rather activated at 100% pulse width.

In addition to the standard light functions, further functions for the exterior lighting are integrated in the footwell module:

- Dynamic beam throw adjustment system
- Lamp monitoring
  - Cold monitoring with lights "OFF"
  - Hot monitoring with lights "ON"
- Visual alarm/feedback
  - Central locking system, Antitheft alarm system, Crash signal
- Special case at "Terminal 15 OFF"
- Emergency operating mode
- Adaptive headlight with
  - Turning lights
  - Adaptive headlight-range adjustment system.

## Schematic, Exterior Lighting Front

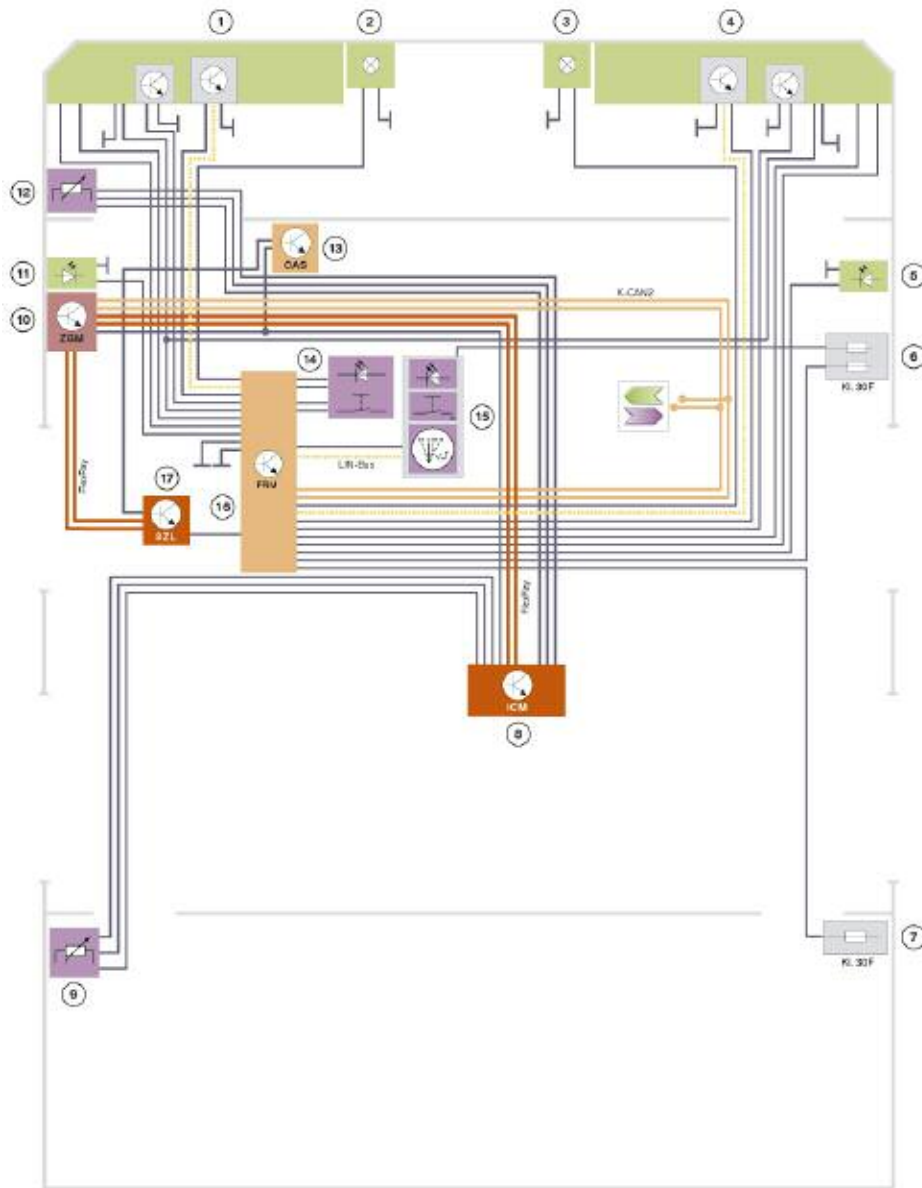

Index	Explanation	Index	Explanation
1	Main headlight, left	12	Ride-height sensor, front
2	Front fog light, left	13	Car Access System 4 (CAS 4)
3	Front fog light, right	14	Hazard warning lights switch
4	Main headlight, right	15	Control panel, light switch
5	Direction indicator repeater, right	16	Footwell module (FRM)
6	Power distribution box, front	17	Steering column switch cluster (SZL)
7	Power distribution box, luggage compartment	K-CAN2	Body CAN2
8	Integrated Chassis Management (ICM)	FlexRay	FlexRay
9	Ride-height sensor, rear	LIN-Bus	Local interconnect network bus
10	Central gateway module (ZGM)	KL. 30F	Terminal 30, fault switched
11	Direction indicator repeater, left		



## Schematic, Exterior Lighting Rear

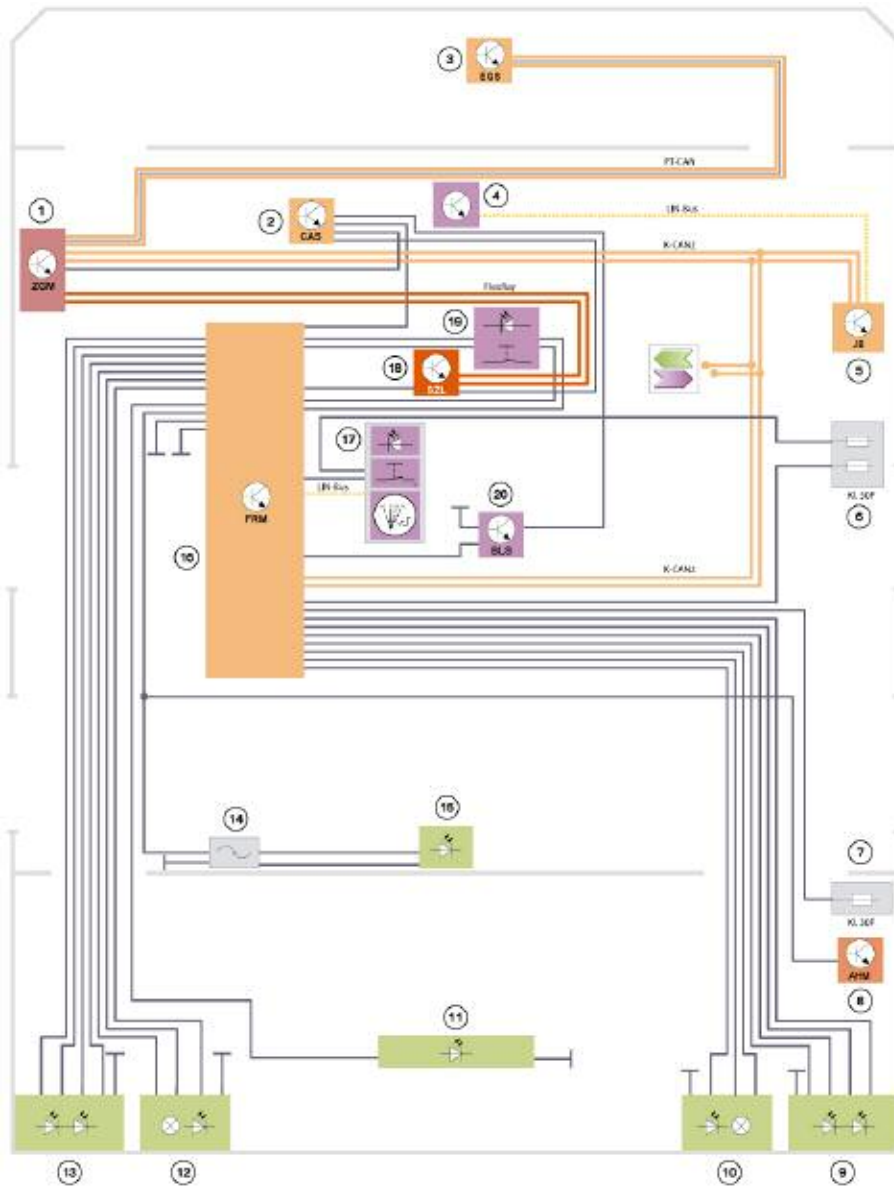

Index	Explanation	Index	Explanation
1	Central Gateway Module (ZGM)	14	Filter with trap circuit
2	Car Access System 4 (CAS 4)	15	Additional brake light
3	Electronic transmission control (EGS)	16	Footwell module (FRM)
4	Rain/drivinglights/condensation/solar sensor*	17	Control panel, light switch
5	Junction box electronics (JB)	18	Steering column switch cluster (SZL)
6	Power distribution box, front	19	Hazard warning switch
7	Power distribution box, luggage compartment	20	Brake light switch
8	Not for U.S.	PT-CAN	Powertrain CAN
9	Outer rear light cluster, right	K-CAN2	Body CAN2
10	Inner rear light cluster, right	FlexRay	FlexRay
11	License plate light	LIN-Bus	Local interconnect network bus
12	Inner rear light cluster, left	KI. 30F	Terminal 30, fault switched
13	Outer rear light cluster, left		



## Adaptive Headlight-range Adjustment

The adaptive headlight-range adjustment function is used when the vehicle is driven through dips and over crests. Through dips, the headlight range is increased without dazzling oncoming vehicles.

Over crests, the throw of the headlight beam is lowered slightly. An oncoming vehicle is not dazzled as much it would have been by standard headlights.

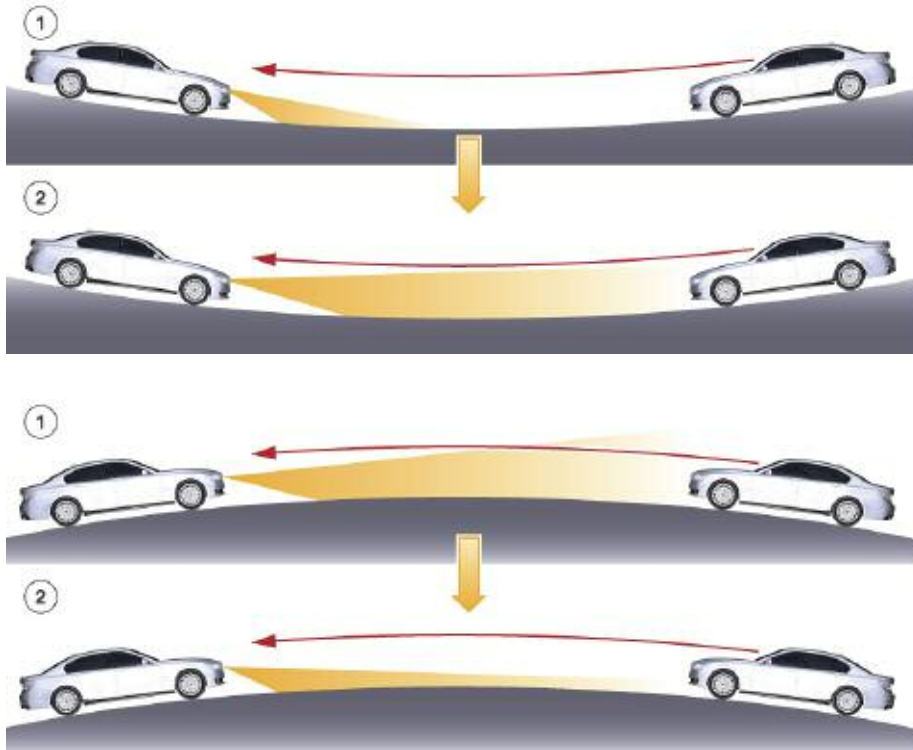

Index	Explanation	Index	Explanation
1	Vehicle without adaptive headlight range adjustment, headlight without increase or decrease in vertical aim	2	Vehicle with adaptive headlight range adjustment, vertical aim of the headlight increased or decreased

The red line represents the eye line of drivers in oncoming traffic. The eye line is the imaginary line along which a driver's eyes move while the vehicle is driven through a dip or over a crest.

The adaptive headlight-range adjustment can be considered similar to an adaptive cornering headlight, albeit turned through 90°.

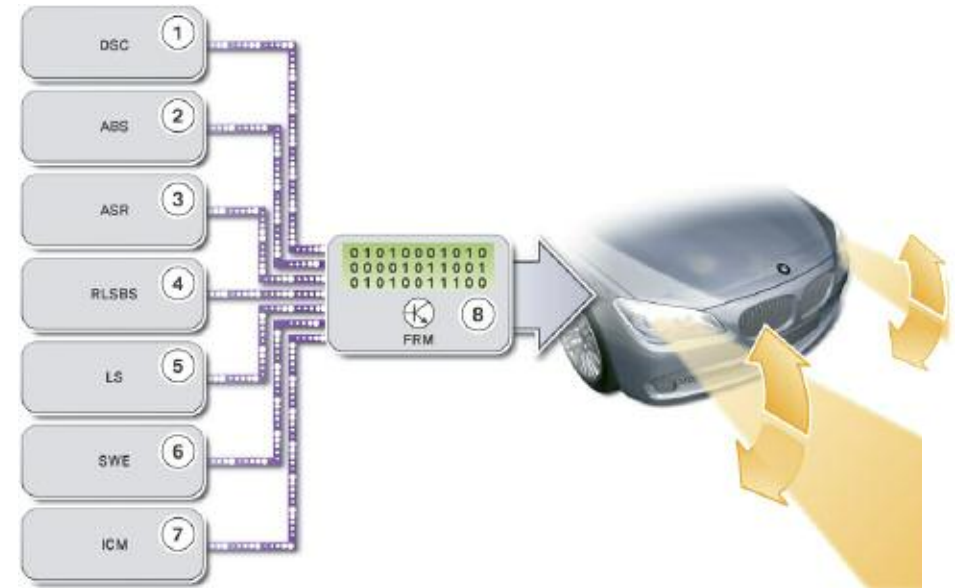

Index	Explanation	Index	Explanation
1	Dynamic Stability Control control intervention	5	Light switch in position "A"
2	Antilock braking system control intervention	6	Poor-route detection system
3	Automatic Stability Control control intervention	7	ICM
4	Rain/light/solar/condensation sensor	8	Footwell module (FRM) Headlight activation adaptive headlight-range adjustment system

## Seats

As far as the seating is concerned, the standard front seats on the F01/F02 are the Multifunction seat (comfort seat).

There is an optional luxury seating package which consists of the Active seat option in addition to the ventilated seats.

The seats can be adjusted from KL 30B ON. The seat-adjustment switch simply has to be pressed in the desired direction. The seats can have up to eight adjustable positions.

A new feature is the passenger-assist function. This is a new function which enables the driver to adjust the front-passenger seat. The passenger assist function is also referred to as the “Gentleman Function”.

### Passenger-assist Function

The passenger-assist function is available from terminal 30B ON. The seat module on the driver's side alone is responsible for the passenger-assist Function.

The button status is read in by the footwell module via the LIN bus and sent via the K-CAN2. The central gateway module transfers the signal to the relevant bus system.

As soon as the driver's seat module SMFA detects an operation request from the passenger-assist function button, it prepares the front-passenger seat module for an adjustment request via the K-CAN.

When the seat adjustment switch on the driver's side is now activated, the seat module on the passenger's side executes the request.

The K-CAN is used for communication between the seat modules. This allows all seat adjustment functions for the front-passenger seat and the memory function to be operated from the driver's seat.

The passenger-assist function is available for the memory seat and the multifunction seat.

The seat module sends the request via the K-CAN to the function indicator for the activated passenger-assist function button in order to switch on the LED in the button.

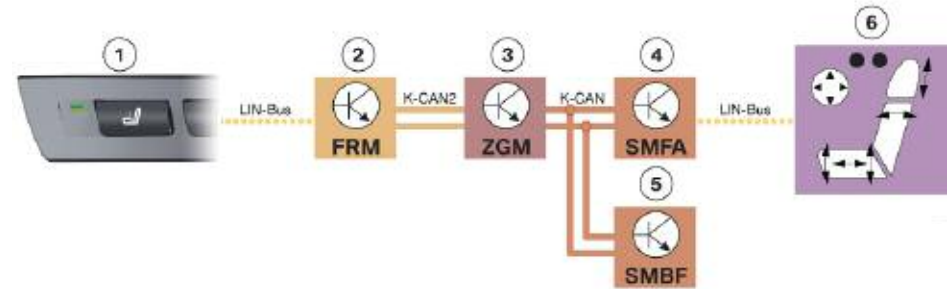

Index	Explanation	Index	Explanation
1	Passenger-assist button	4	Driver's seat module (SMFA)
2	Footwell module (FRM)	5	Passenger seat module (SMBF)
3	Central Gateway module (ZGM)	6	Button, seat functions, driver's seat

## Rear Seats

The rear seats on the F01 are available with a rear luxury seating package which consists of rear seat ventilation and comfort seats.

An additional stand alone option is for the rear seat massage function which must be ordered in conjunction with the rear seat luxury package.

## Rear Comfort Seat, Driver's Side

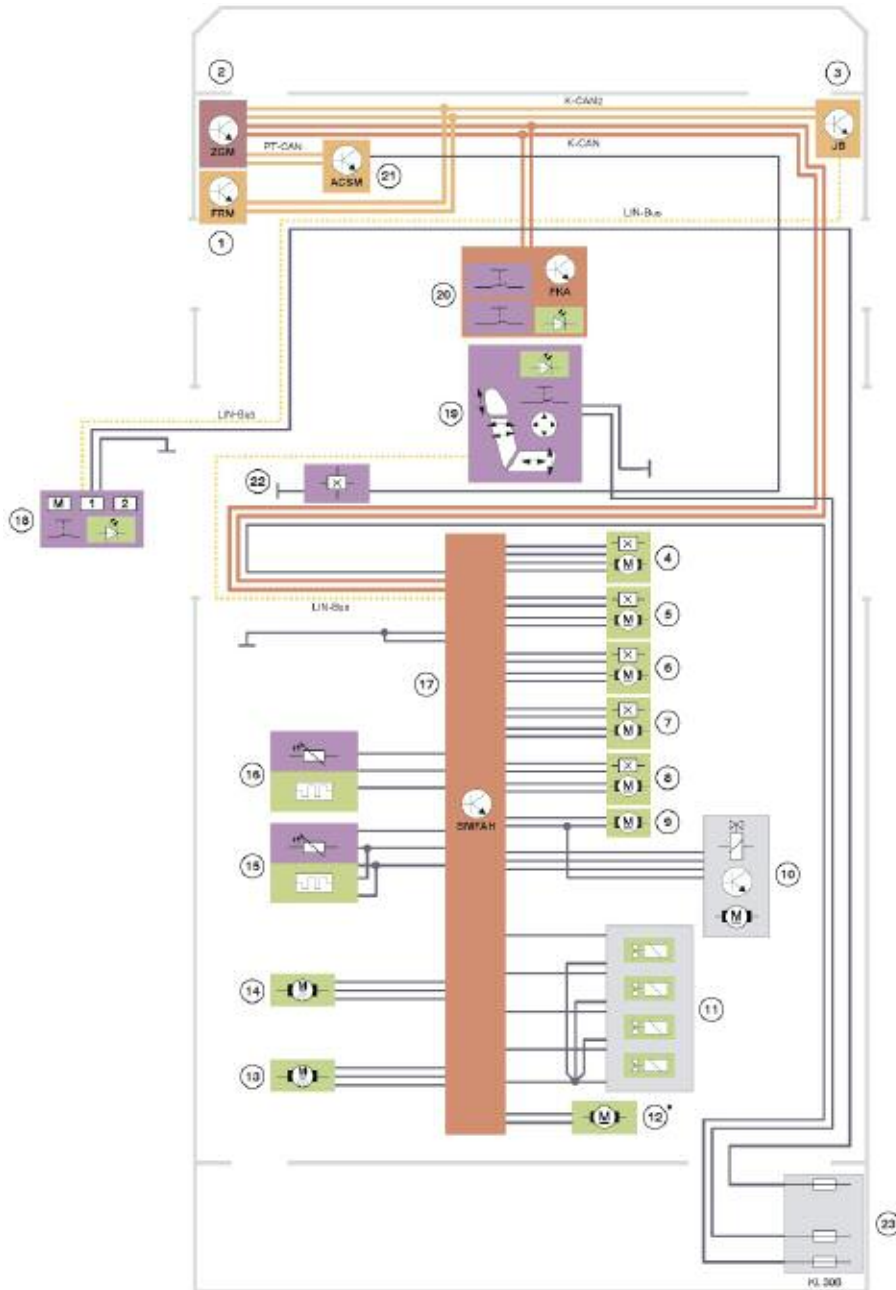

Index	Explanation	Index	Explanation
1	Footwell module (FRM)	15	Seat-heating pad, backrest surface
2	Central gateway module (ZGM)	16	Seat-heating pad, seat surface
3	Junction box electronics (JB)	17	Seat module, driver's side, rear (SMFAH)
4	Motor, longitudinal seat adjustment (SLV)	18	Button block in the armrest, driver's side
5	Motor, seat-inclination adjustment (SNV)	19	Buttons, seat functions, driver's seat
6	Motor, backrest-inclination adjustment (LNV)	20	Integrated automatic heating and air conditioning (IHKA)
7	Motor, upper backrest adjustment (LKV)	21	Crash Safety Module (ACSM)
8	Motor, head-restraint height adjustment (KHV)	22	Seatbelt-buckle switch
9	Pump, lumbar support/massage function	23	Luggage compartment power distribution box
10	Pressure distribution module, massage/lumbar support	K-CAN2	Body CAN2
11	Solenoid valves for lumbar support	K-CAN	Body CAN
12	Pump for lumbar support*	LIN-Bus	Local interconnect network bus
13	Fan, active seat ventilation, backrest surface	KI. 30B	Terminal 30 basic operation
14	Fan, active seat ventilation, seat surface		

### Massage function in Rear-compartment Comfort Seat

The F01/F02 is the first BMW vehicle to have the rear-compartment massage option.

An electropneumatic system is used to implement the massage function. The massage function can be activated from terminal 30B ON. The seat module is integrated into the backrest of the seat concerned and is responsible for the massage function.

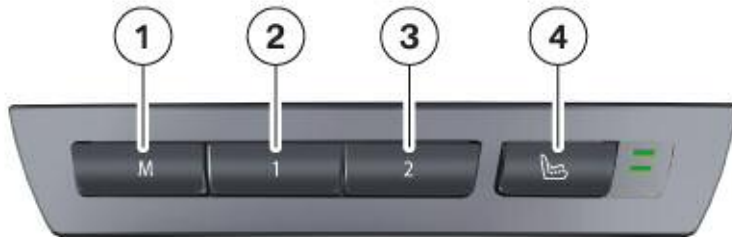

Index	Explanation
1	M button
2	Button 1
3	Button 2
4	Massage function button

The buttons for the massage function are connected via the LIN bus to the junction box electronics.

The junction box electronics evaluate the status of the massage button and send the status via the K-CAN2.

The central gateway module transfers the signal to the K-CAN. This allows the seat module to receive the current status of the buttons. The seat module evaluates the status, activates the massage function, and monitors it.

In the backrest of the comfort seat, there is a massage pad for the massage function. Pressing the button starts the massage function at the maximum massage intensity.

Pressing the button again switches it to a lower massage intensity level. Pressing the button once again switches the massage function off.

If the button is pressed for longer than 1.2 seconds during the massage function, the massage function will be switched off.

In order to indicate that the massage function has been activated, the seat module sends the request to switch on the LEDs in the button.

The signal terminal 58g ON is made available through the footwell module. The junction box electronics pass on terminal 58g ON to the button. The button then switches the back lighting on.

## ■ Massage

The massage function is divided into massage cycles. A massage cycle consists of the massage and includes back mobilization and lasts approximately 64 seconds. After this, a new massage cycle begins.

There are twelve massage cushions that help to relieve tension in the back muscles through a wave-like motion along the backrest from top to bottom.

The wave-type motion is created by inflating and deflating the massage cushions. The pressure distribution module activates the massage cushions in pairs simultaneously.

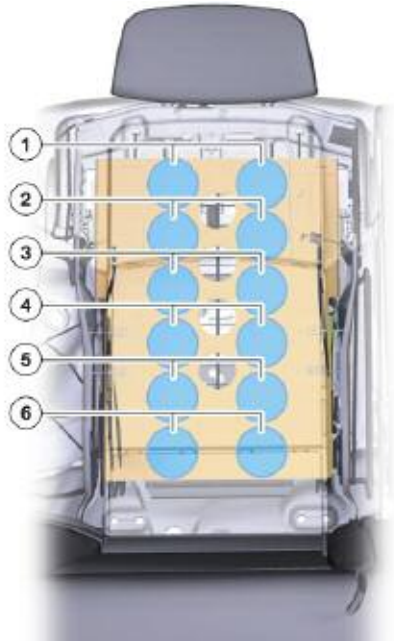

Index	Explanation	Index	Explanation
1	Massage cushion pair 1	4	Massage cushion pair 4
2	Massage cushion pair 2	5	Massage cushion pair 5
3	Massage cushion pair 3	6	Massage cushion pair 6

## ■ Mobilization

The massage is followed by a mobilization therapy for the back. The mobilization cushions are simultaneously inflated and deflated periodically and sectionally. For example, the mobilization cushions in the right shoulder and right lumbar as well as the mobilization cushions in the left thorax are pumped up and deflated. Following that, the opposite side is inflated and deflated.

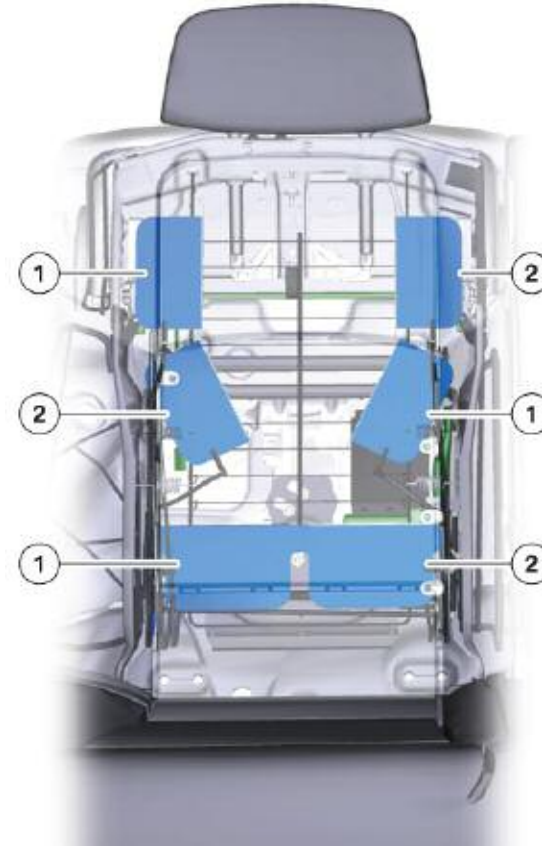

Index	Explanation	Index	Explanation
1	Mobilization cushions, right shoulder, left thorax, right lumbar	2	Mobilization cushions, left shoulder, right thorax, left lumbar



### Active Seat Ventilation for the Rear Comfort Seat

In the F01/F02, a new concept has been introduced for the active seat ventilation. This concept requires only two fans for each seat.

The integrated automatic heating and air conditioning system provides the vehicle with climate-controlled air. This means there is sufficient fresh and climate-controlled air in the footwell in front of the rear seats. The fans draw some air from the footwell. The drawn-in air is routed via each air-conditioning pad to the seat and the backrest.



Index	Explanation	Index	Explanation
1	Button, active seat ventilation, rear driver's side	2	Button, active seat ventilation, rear passenger's side

The seat module in the seat concerned has sole responsibility for the active seat ventilation function. Stage 3 is engaged when the button is pressed for the first time. This sets a high fan stage for seat and backrest.

The next fan setting or OFF is selected on further pressing of the button.

The active seat ventilation relies on the 4-zone automatic air conditioning. The buttons for the active seat ventilation are in the control panel of the automatic rear-compartment air conditioning.

The air intensity of the active seat ventilation is coupled to the fan setting of the automatic rear-compartment air conditioning. This makes it possible to harmonize the fan noises in the rear compartment. The active seat ventilation therefore reaches its maximum value, when the automatic rear-compartment air conditioning is set to the maximum fan setting.

A/C Stage	Fans seat	Fans, backrest
3	High	High
2	High	Low
1	Low	Low
0	OFF	OFF

If the automatic rear-compartment air conditioning is not switched on, then the fans are activated based on a characteristic map that is stored in each seat module.

## Air-conditioning Pad

The air-conditioning pad has openings in the area of the seat and backrest surfaces. Air can be drawn in through the openings in order to control the temperature of the seat cover.

Special covers are required for active seat ventilation. The covers have very small air outlets. The air drawn in by the fans can flow through the air outlets. This cools the seat cover and ensures that the temperature of the seat cover remains pleasant.

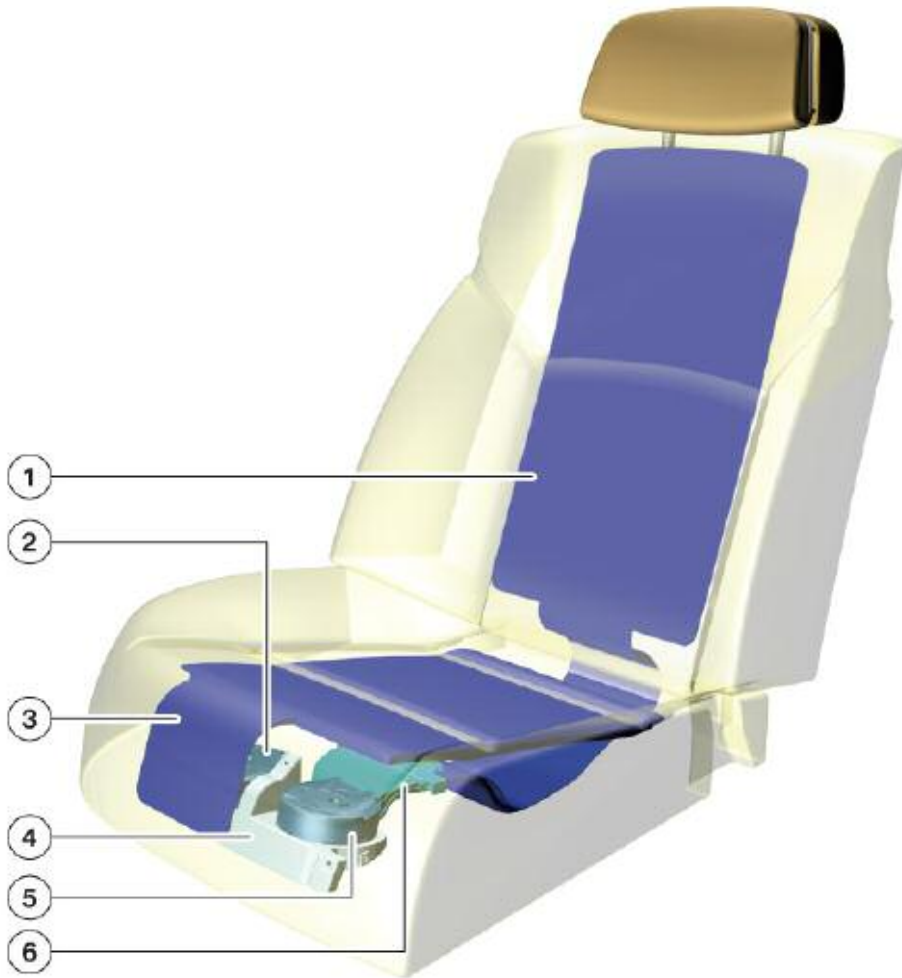

Index	Explanation	Index	Explanation
1	Air conditioning pad, backrest surface	4	Noise dampener for noise reduction
2	Fans, seat ventilation	5	Fans, backrest ventilation
3	Air conditioning pad, seat surface	6	Adapters for air conditioning pad, backrest surface

NOTES

PAGE