



SUBARU

SERVICE BULLETIN

SUBARU CORPORATION
Overseas Service Dept.
Japan.

Pub. No. SB18-200
Issued: December 72018
(SBR Ref. B2018-214)

Subject:	Parts Change Information: New PLATE BMPR SD for BRZ Front Bumper
Applicable part category in Service Manual:	Body & Electrical/WIRING SYSTEM > EXTERIOR/INTERIOR TRIM > Front Bumper
Applicable Parts name in Subaru Parts System:	PLATE BMPR SD
Foreword:	<p>This service bulletin is to inform you the availability of new part, PLATE BMPR SD (metal plate) for BRZ Front Bumper as countermeasure of side splitting part coming loose.</p> <p>For the repairs, use the PLATE BMPR SD (metal plate) as a reinforcing part, and follows the work procedure provided on this Service Bulletin.</p>

1. Applicable Vehicle

Applicable Vehicle	Specification	MY
BRZ	ALL	13 -

This information is NOT applicable to SIA production.

This information is NOT applicable to Malaysia CKD production.

2. Description of Symptom and Improvement

Customers may complain about the following symptom. A countermeasure to eliminate the symptom has been set up. Its contents are as follows.

Symptom	Details of Symptom and Improvement
On some certain vehicles, the side view of the front bumper may come loose.	<p>Details of Symptom, Cause: The side part of the front bumper may come loose. This is because the claw of the front bumper rubs against the bracket corner and damages it, resulting in the poor fitting force.</p> <p>Improvement Content: Please install the PLATE BMPR SD (metal plate), which has been newly set as a reinforcing part, to reinforce the affected area. For the working procedure, please refer to this service bulletin.</p>

2-1 Details of affected area

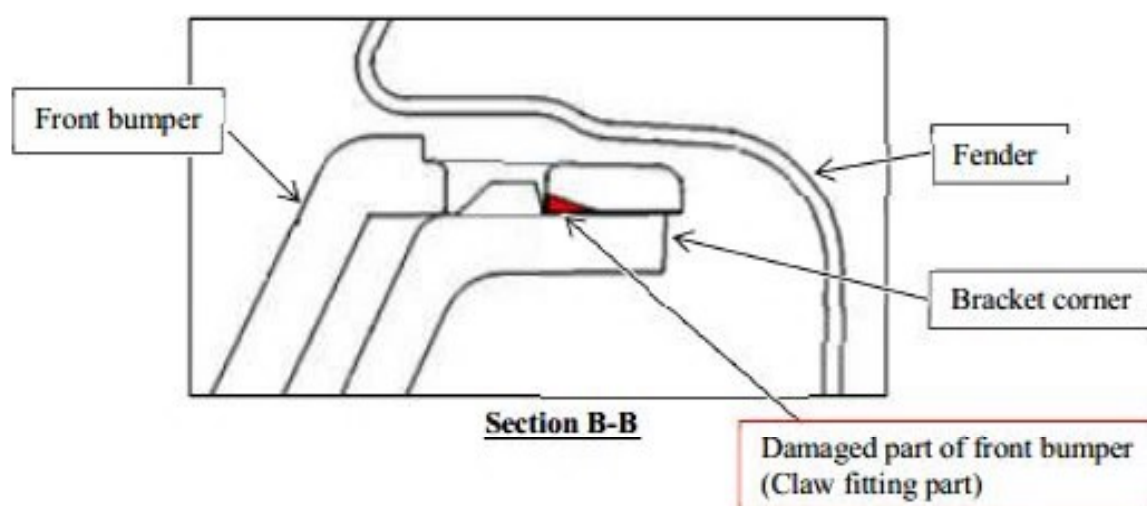
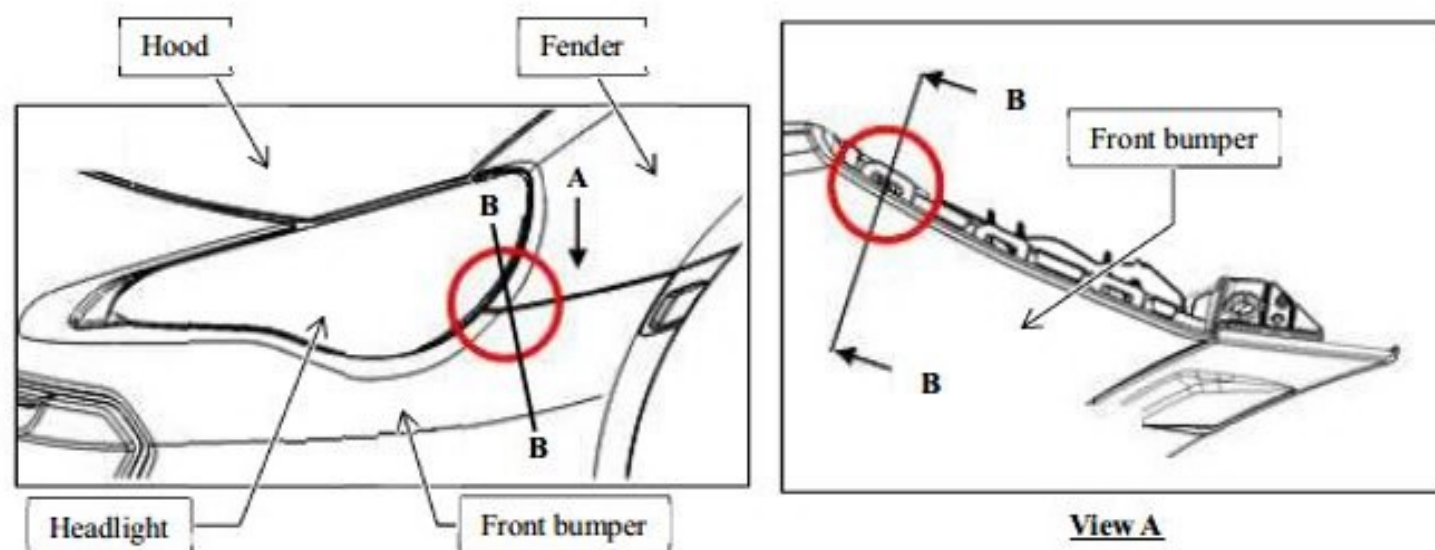

3. Production Change Information (Starting VIN)

Applicable Model	Market and specifications			Starting number (VIN)
	BRZ	North America	Coupe	
Europe, General		Coupe	LHD	TBD
		Coupe	RHD	TBD

For more detailed information about what each letter or number of VIN represents, refer to <Identification Section> of Service Manual.

4. Parts Information and Interchangeability

No	New Parts		Interchangeability	Old Parts	Remarks
1.	Part No.	57722CA030	New part to Old car: Yes	-	BRZ 13MY - ALL
	Part name	PLATE BMPR SD		-	
	Note	Newly set up 1 each for left and right		-	

5. Working Procedure

1. Remove the front bumper.

For the removing procedure, please refer to the service manuals.

2. Judge whether the front bumper is reusable or not.

“Judgment Criteria”

The front bumper that satisfies the following conditions is judged to be reusable.

- There is no crack, whitening or damage (excluding damage of the claw fitting part due to the rubbing) on the affected area.
- There is no deformation on the claw fitting part. (Refer to View C)
- The dimension is within the reference value range (4.5 mm or less). (Refer to Section E-E)

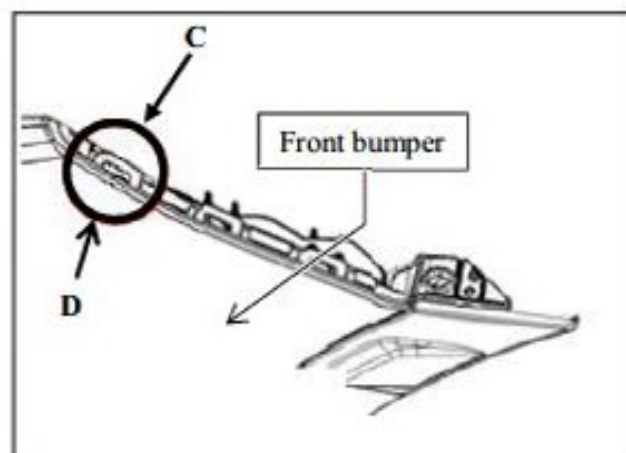
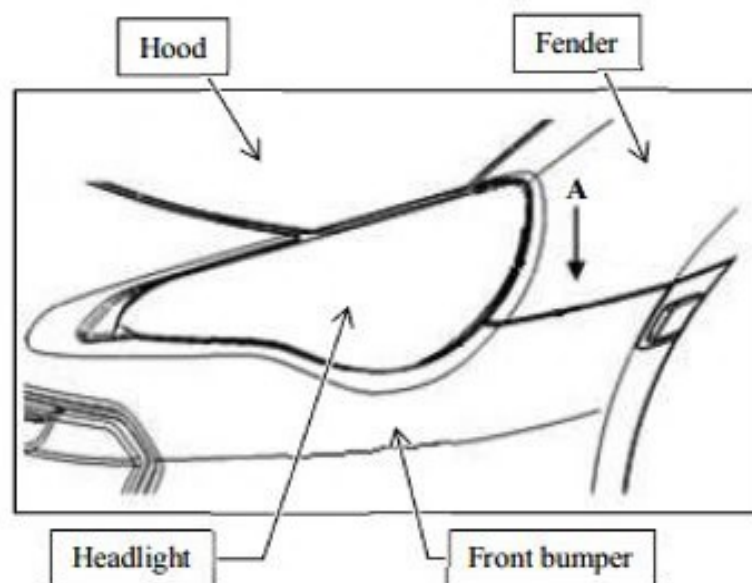

View A

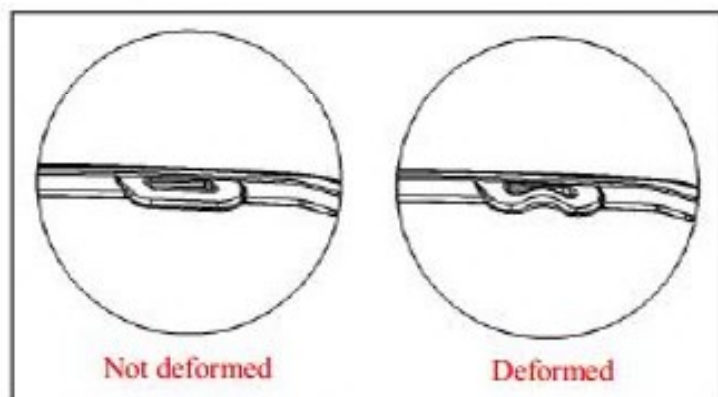

View C

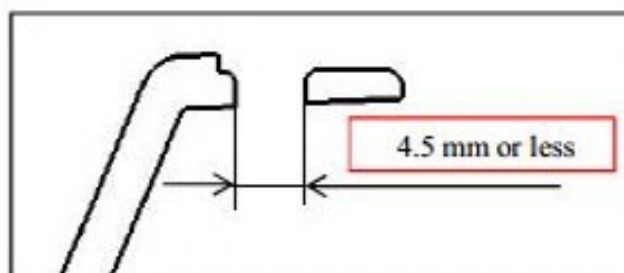
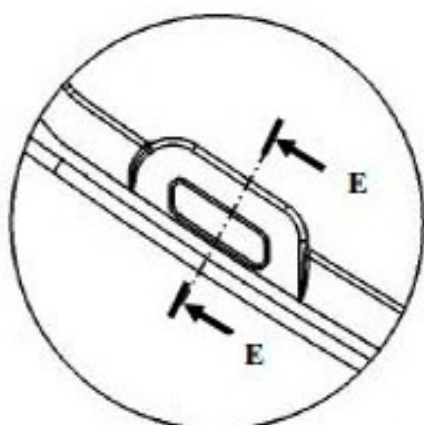

3. Rinse off the dirt on the affected area of the front bumper with water.
4. Apply neutral detergent between the flange parts of the PLATE BMPR SD.

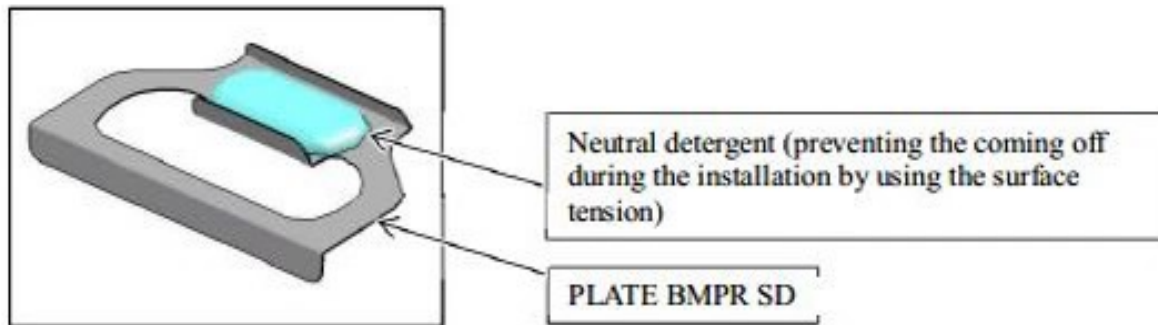

5. Install the PLATE BMPR SD on the back face (RH, LH) of the front bumper.

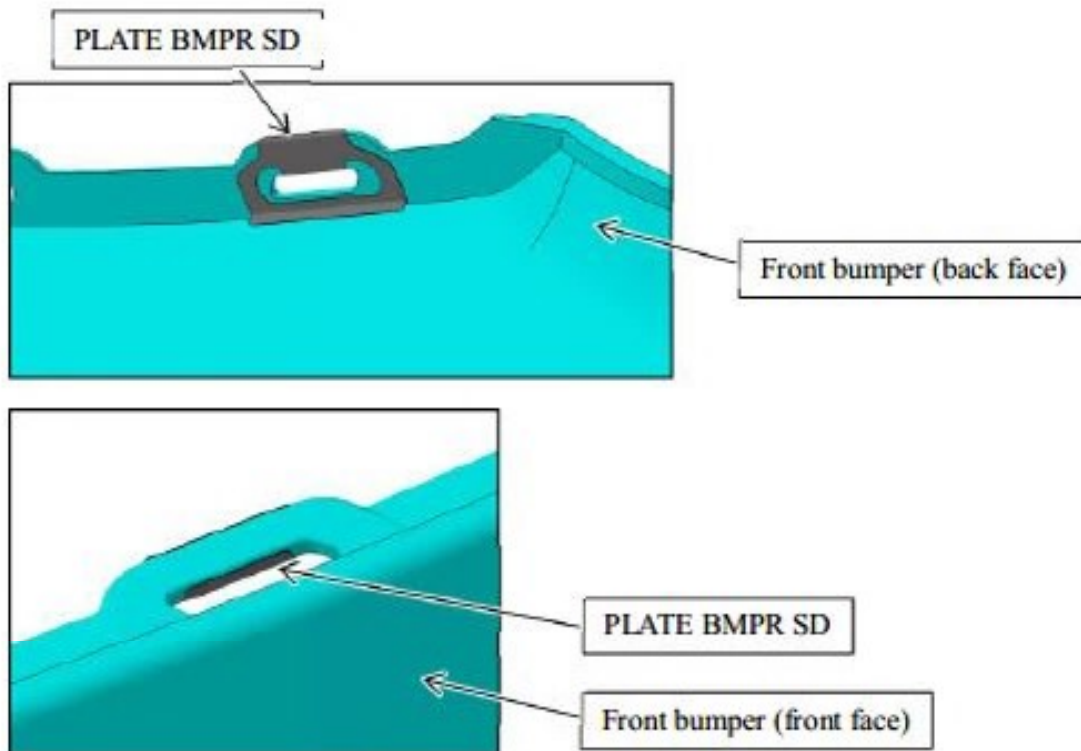

NOTE:

If there is a burr on the front bumper and it is difficult to install the PLATE BMPR SD, remove the burr on the front bumper using a metal file, etc. Be careful not to file other parts than the burr.

6. Install the front bumper.

For the installation procedure, refer to the service manuals.

Be careful: the PLATE BMPR SD may come off if it contacts the peripheral parts multiple times at the installation.

7. Visually confirm that the PLATE BMPR SD is installed from the gap of the side splitting part of the front bumper.

8. Rinse off the neutral detergent applied to PLATE BMPR SDS by pouring water onto the side splitting part of the front bumper.

CAUTION:

Take care the edge of the PLATE BMPR SD that is sharp edge.

Procedure in the Service Manual is not changed, also the tightening torque is not changed.

Please refer to the SUBARU Service Manual.

6. Labour Time

In case of Front bumper is reused: 0.5 h

In case of Front bumper is replaced: 0.8 h

END

**CAUTION: VEHICLE SERVICING PERFORMED BY UNTRAINED PERSONS COULD RESULT IN
SERIOUS INJURY TO THOSE PERSONS OR TO OTHERS.**

Subaru Service Bulletins are intended for use by professional technicians **ONLY**. They are written to inform those technicians of conditions that may occur in some vehicles, or to provide information that could assist in the proper servicing of the vehicle. Properly trained technicians have the equipment, tools, safety instructions, and know-how to do the job correctly and safely. If a condition is described, **DO NOT** assume that this Service Bulletin applies to your vehicle, or that your vehicle will have that condition.